

INSTRUCTION MANUAL

R. L. DRAKE COMPANY...

T-4X TRANSMITTER



T-4 RECITER



PRICE:
\$200

STANDARD WARRANTY

The R. L. Drake Company warrants each new radio product manufactured by it to be free from defective material and workmanship and agrees to remedy any such defect or to furnish a new part in exchange for any part of any unit of its manufacture which under normal installation, use, and service, discloses such defect, provided the unit is delivered by the owner to us or to our authorized radio dealer or wholesaler from whom purchased, intact, for our examination, with all transportation charges prepaid to our factory within ninety days from the date of sale to original purchaser and provided that such examination discloses in our judgement that it is thus defective.

This warranty does not extend to any of our radio products which have been subjected to misuse, neglect, accident, incorrect wiring not our own, improper installation, or to use in violation of instructions furnished by us, nor in cases where the serial number thereof has been removed, defaced or changed, nor to units used with accessories not manufactured or recommended by us.

Any part of a unit approved for remedy or exchange hereunder will be remedied or exchanged by the authorized radio dealer or wholesaler without charge to the owner.

This warranty is in lieu of all other warranties expressed or implied and no representative or person is authorized to assume for us any other liability in connection with the sale of our radio products.

The R. L. Drake Company reserves the right to make any improvements to its products which it may deem desirable without obligating itself to install such improvements in its previously manufactured products.

TABLE OF CONTENTS

General Specifications	3
Tube and Semiconductor Complement	4
I Description	5
II Installation Instructions	6
A. Unpacking	6
B. Location	6
C. Power Requirements	6
D. Antenna Requirements	6
E. Receiver Muting	7
F. Receiver Antenna Switching	7
G. Anti VOX and Sidetone	7
H. R-4 Injection	7
I. Microphone Requirements	7
J. Linear Amplifier Connection	8
K. Transceive Alignment	8
III Control Functions	11
A. T-4X -Only (Front)	11
B. T-4 and T-4X Front Controls & Jacks	12
C. Side Controls & Jacks (T-4 and T-4X)	13
D. Rear Connections	13
E. Inside Controls	13
IV Tuning Procedure	15
A. Sias Adjustment	15
B. Tune Up on Desired Band	15
C. Carrier Balance Adjustment	16
D. Dial Calibration On the T-4X	16
V Operation	17
A. Voice Controlled and Push to Talk Operation on SSB	17
B. CW Operation	17
C. AM Operation	18
D. Spotting	18
E. Transceiving	18
F. Operation on Accessory Frequencies	20
G. RTTY Operation	20
H. Crystal Controlled Operation	24
I. Operation With a Linear Amplifier	24

VI	Theory of Operation	26	
VII	Service Data	29	
	A.	Removing Top Cover	29
	B.	Removing Bottom Cover	29
	C.	Tube Replacement	29
	D.	Troubleshooting	29
VIII	Alignment Instructions	36	
	A.	Adjustment of RF and Mixer Stages	36
	B.	Carrier Oscillator, Filter Match and Balanced Modulator	38
	C.	Neutralizing Final Amplifier	38
	D.	Crystal Oscillator Check	39
	E.	T-4X VFO Adjustment	39
IX	AC-3 Power Supply	40	

CHARTS AND ILLUSTRATIONS

Fig. # 1	Connecting the T-4 or T-4X to R-4 Receiver	9
Fig. # 2	Connecting the T-4 or T-4X to a Linear Amplifier	9
Fig. # 3	Connecting the T-4X to a Receiver other Than the R-4	10
Fig. # 4	Viewing Angle Options	10
Fig. # 5	Side View T-4 and T-4X	14
Fig. # 6	Rear View T-4 and T-4X	14
Fig. # 7	Crystal Frequency Chart	21
Fig. # 8	R. F. TUNE Curves	23
Fig. # 9	Block Diagram T-4X	28
Fig. # 10	Resistance Chart	30
Fig. # 11	Voltage Chart	31
Fig. # 12	Top View T-4	32
Fig. # 13	Bottom View T-4	33
Fig. # 14	Top View T-4X	34
Fig. # 15	Bottom View T-4X	35
Fig. # 16	Crystal Filter Attenuation	39
Fig. # 17	AC-3 Schematic Diagram	40
Fig. # 18	T-4 Schematic Diagram	41
Fig. # 19	T-4X Schematic Diagram	42

GENERAL SPECIFICATIONS

T-4X ONLY

FREQUENCY COVERAGE: 3.5 - 4.0 mc, 7.0 - 7.5 mc, 14.0 - 14.5 mc, 21.0 - 21.5 mc, and 28.5 - 29.0 mc with crystals supplied. Four accessory crystal sockets are provided for coverage of additional 500 Kc ranges between 1.8 and 30.0 mc with the following exceptions: 2.3 - 3.0 mc, 5.0 - 6.0 mc, and 10.5 - 12.0 mc.

DIAL CALIBRATION: Main dial calibrated 0 to 500 Kc and 500 to 1000 Kc in 5 Kc divisions. Vernier dial calibrated 0 to 25 Kc in 1 Kc divisions.

CALIBRATION ACCURACY: Better than 1 Kc when calibrated to nearest 100 Kc point.

STABILITY: Less than 100 cycles after warm up. Less than 100 cycles with 10% change in line voltage.

T-4 and T-4X

MODES OF OPERATION:

- SSB:** Upper or lower sideband on all bands, VOX or push to talk.
- CW:** Grid-block keying. VOX circuit is keyed for automatic transmit receive switching. Sidetone oscillator is keyed for monitoring. Shifted carrier system has no spurious output.
- AM:** Controlled carrier AM modulation is built in. This system is compatible with SSB linear amplifiers. VOX or push to talk.
- RTTY:** (T-4X only) VFO easily adaptable to FSK. Signal frequency shifts same direction on all bands and same amount on all bands with a given dial setting.

SIDEBAND SUPPRESSION: 40 DB above 750 CPS.

CARRIER SUPPRESSION: 60 DB or better.

AVERAGE DISTORTION PRODUCTS: In excess of 30 DB down.

FREQUENCY RESPONSE: 300 to 2600 cycles at 6 DB down.

INPUT POWER: SSB and AM - 200 watts P.E.P., CW - 200 watts.

OUTPUT IMPEDANCE: Nominal 52 ohms adjustable with pi network. (SWR should be 2:1 or less.)

MICROPHONE INPUT: High impedance.

AGC: Operates on SSB to prevent flat topping due to overdrive.

CONTROLS AND JACKS:

Front:

T-4X Only - Main tuning, accessory crystal switch, and function switch.

T-4 and T-4X - Sideband selector, band switch, RF tune, gain, plate tuning, plate loading, transceive switch, plate current/relative output meter switch and microphone jack.

Side:

T-4 and T-4X - Anti-VOX/Sidetone gain, and VOX gain.

T-4X Only - XTAL control socket.

Rear: Power connector, mute jack, receiver antenna jack, Anti-VOX/Sidetone jack, key jack, antenna connector, ground post, and R-4 injection jack.

Inside: Carrier balance control.

DIMENSIONS: 5-1/2" high, 10-3/4" wide, cabinet depth 11-5/8", overall length 12-1/4"; weight of T-4, 12 lbs. 7 oz.; weight of T-4X, 14 lbs. 1 oz.

POWER REQUIREMENTS: AC-3 POWER SUPPLY

1. 650 volts at 200 ma average and 330 ma maximum with 10% regulation from 66 ma to 330 ma and maximum ripple of less than 1%.
2. 250 volts at 120 ma with 10% regulation from 82 ma to 120 ma. This includes the effect of the 650 volt supply change if both voltages are obtained from the same transformer. Maximum ripple must be less than 1/4%.
3. -45 to -65 VDC adjustable filtered bias into 33 K ohm load.
4. 12.6 volts AC or DC at 3 amps.

TUBE AND SEMICONDUCTOR COMPLEMENT:

<u>T-4X Only</u>	<u>NUMBER</u>	<u>FUNCTION</u>
	2N3394	VFO
	2N3394	VFO Buffer
	2N3394	XTAL OSC
	ERV-10	Voltage Regulator
<u>T-4 and T-4X</u>	<u>NUMBER</u>	<u>FUNCTION</u>
	12BA6	I.F. amplifier
	12BY7	Driver
	2 - 6JB6	Power Amp.
	12AX7	Mic amp/sidetone osc
	6EV7	VOX amp
	6HS6	Premixer
	6AU6	AM modulator
	12AX7	AGC amp. Carrier osc
	OA2	Voltage regulator
	2 - SG952A	VOX and Anti-VOX rectifiers
	4 - IN270	Balance modulator
	SG952A	Trigger
	IN270	Output meter detector
	6AU6	Mixer

I DESCRIPTION

The R. L. Drake model T-4 Reciter and T-4X Transmitter offer selectable single sideband, semi break-in CW, and controlled carrier AM transmission with capabilities for covering the 160 through 10 meters Amateur bands as well as many other non-ham band frequencies (MARS coverage, etc.).

The T-4 Reciter is designed to be used with our model R-4 Receiver, for transceiving on the frequency to which the R-4 is tuned.

The T-4X is a complete transmitter which may be used for transceiving with the R-4 Receiver or for independent receive/transmit usage. A front panel switch on the T-4X selects between transceiving with the T-4X VFO, the R-4 VFO, or independent frequency control.

The T-4 only may be crystal controlled in the transmit mode for novice, MARS, DX, or net operation.

Both units have CW sidetone oscillator, automatic transmit receive switching on CW, transmitting AGC to prevent flat topping, plate meter/relative output indicator, two crystal lattice filters for sideband selection, receiver muting, receiver antenna switching, and VOX and PTT on AM and SSB, all built in for the optimum in operating convenience and economy.

The units provide 200 watts P.E.P. input on AM and SSB and 200 watts input on CW for plenty of punch when run barefoot and more than ample drive for grounded grid linear amplifiers.

Compact size and continuity of styling combine for eye appeal and convenience.

II INSTALLATION INSTRUCTIONS

A. UNPACKING

Carefully remove your T-4 or T-4X from its packing carton and examine it closely for signs of shipping damage. Should any be apparent, notify the delivering carrier immediately, stating the full extent of the damage.

Fill out and mail the enclosed registration card so that your warranty will be effective.

Save the packing material. You may need it later for reshipment or storage.

Inspect the packing material closely before putting it away to be sure you have not overlooked the accessory hardware packed with the unit.

B. LOCATION

In general, the location of the T-4 or T-4X is not critical. However, care should be taken to insure that space is provided around the unit to allow adequate air circulation. Extremely hot locations, such as near radiators or heating units, should be avoided. Do not cover the top of the unit with books, papers, or pieces of equipment, or overheating may result.

C. POWER REQUIREMENTS

The T-4 and T-4X should both be used with our model AC-3 power supply. This supply is designed to supply the proper voltages and currents for these units from 120/240 VAC 50/60 cycles and will fit inside the MS-4 speaker, used with your R-4 Receiver.

D. ANTENNA REQUIREMENTS

The T-4 and T-4X are designed for use with antennas resonant on the operating frequency and having approximate impedances of from 30 to 100 ohms. Although there are many types of antennas which will meet this requirement, the simplest is a one half (1/2) wave dipole, center fed with 52 ohm coax. For a detailed discussion on antennas, we suggest you refer to the ARRL Antenna Book or The Radio Amateur's Handbook.

Antenna connection to the T-4 and T-4X is provided at the SO-239 coax connector located on the rear of the shielded compartment housing the final amplifier components.

CAUTION: NEVER ATTEMPT TO OPERATE THE T-4 or T-4X WITHOUT FIRST CONNECTING TO AN ANTENNA OR 52 OHM DUMMY LOAD OF SUFFICIENT POWER HANDLING CAPACITY OR SERIOUS DAMAGE CAN RESULT.
--

E. RECEIVER MUTING

The RCVR MUTE jack provides a short circuit to ground on receive and an open circuit on transmit. This jack can be connected directly to the Mute jack on the R-4 Receiver with one of the hook up cables provided.

F. RECEIVER ANTENNA SWITCHING

The T-4 and T-4X contain built in receiver antenna switching. Simply connect one of the coax cables provided from the RCVR ANT jack on the rear of the T-4 or T-4X chassis to the receiver antenna terminals.

G. ANTI VOX & SIDETONE

The Anti Vox input and CW sidetone output utilize the ANTI VOX/SIDETONE jack on the rear of the T-4 and T-4X chassis for connecting to the receiver and speaker. The impedance at this point is approximately 5000 ohms. To connect to the R-4 Receiver, simply couple the ANTI VOX/SIDETONE jack to the ANTI VOX jack on the rear of the R-4 Chassis with one of the cables provided. If the R-4 is not used, it will be necessary to use a 5000 ohm to 4 ohm audio output transformer between the ANTI VOX/SIDETONE jack and the speaker terminal of the receiver. The high impedance winding of the transformer should, of course, be connected to the ANTI VOX/SIDETONE jack and the low impedance winding should be connected to the receiver speaker terminals in parallel with the speaker. An alternate connection for this jack would be to the plate of the receiver audio output tube (a DC blocking capacitor is provided in T-4 and T-4X).

H. R-4 INJECTION

In order to transceive with the R-4 Receiver, it will be necessary to run a cable from the INJ. jack on the rear of the T-4 or T-4X chassis to the INJ. jack on top of the R-4 chassis. It will be necessary to remove the top cover of the R-4 to gain access to this jack. This cable will provide both RF and control voltage.

I. MICROPHONE REQUIREMENTS

A microphone with a wide and flat frequency response will enable you to obtain peak performance from your T-4 and T-4X. For good VOX (voice control) operation, it is desirable for the mike to have a cardioid pattern to reduce pickup from the back and sides. This enables you to operate with higher receiver audio gain, giving better VOX operation and reducing echoes, reverberation, and noise pickup. Microphones with limited low or high frequency response and with peaks in the voice range should be avoided.

A three conductor microphone plug (Switchcraft type S-260) is provided with the T-4 and T-4X. The microphone must be connected as shown here for proper VOX and push to talk operation. Many microphones that are furnished with a switch are wired so that the microphone cartridge is open or short circuited unless the switch is depressed. This function must be defeated or VOX operation will be impossible.

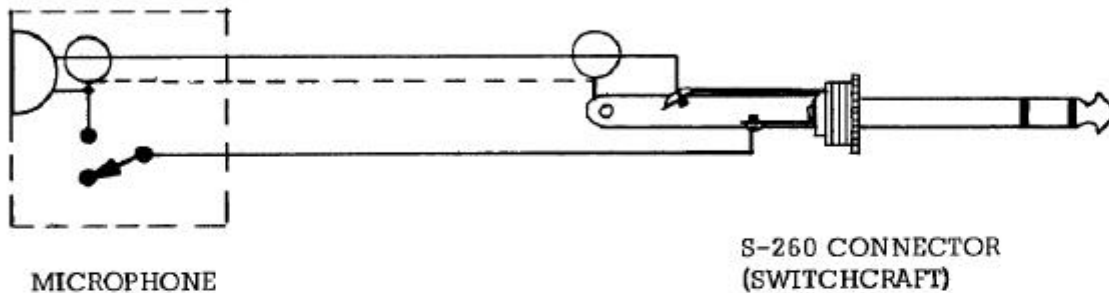

J. LINEAR AMPLIFIER CONNECTION

In order to use your T-4 and T-4X with a linear amplifier, connect as per figure 3. Note that if the linear amplifier has negative going transmitting AGC voltage available, it can be connected to pin 3 of the power connector to prevent the linear from flat topping.

K. TRANSCIVE ALIGNMENT

In order to insure that you are receiving and transceiving on exactly the same frequency when in the transceive mode, the following adjustments will be necessary to the R-4 Receiver.

1. Tune up the T-4 or T-4X as described under "Tuning Procedure". (If T-4X is used, set TRANSCIVE switch to RCVR).
2. Set the R-4 FUNCTION switch to "ON", set the passband selector lever to 4.8 Kc and set the passband knob to the center of the longest line.
3. With the transmitter FUNCTION switch still on TUNE, observe the pitch of the audio tone.
4. This tone should be the same pitch when the transmitter SIDEBAND switch is switched back and forth between upper and lower. If this is not the case, adjust C-61 on top of the R-4 chassis until this condition is satisfactory.

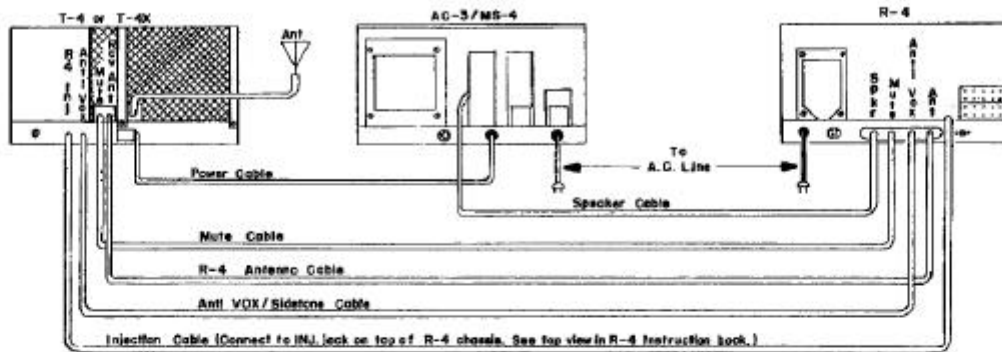

FIG. 1 CONNECTING THE T-4 OR T-4X TO THE R-4 RECEIVER, AC-3 POWER SUPPLY, AND MS-4 SPEAKER.

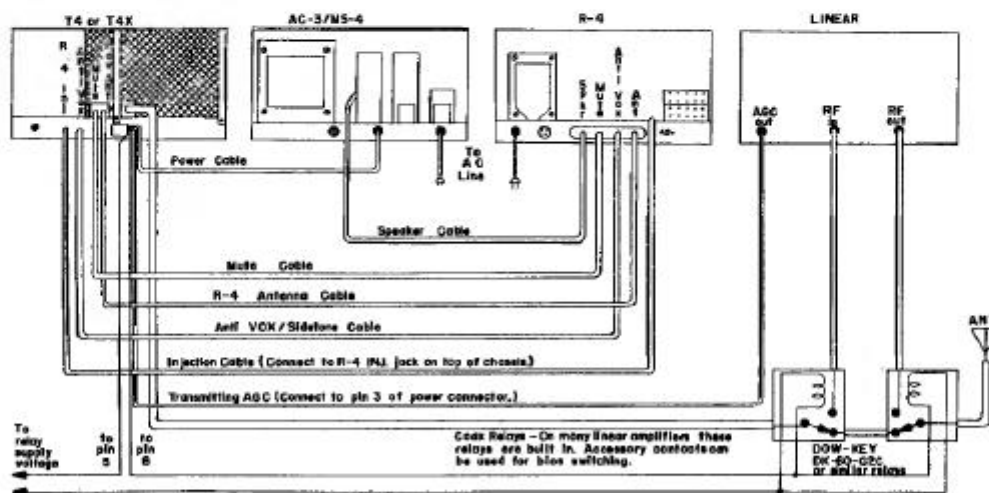

FIG. 2 CONNECTING THE T-4 OR T-4X TO A LINEAR AMPLIFIER

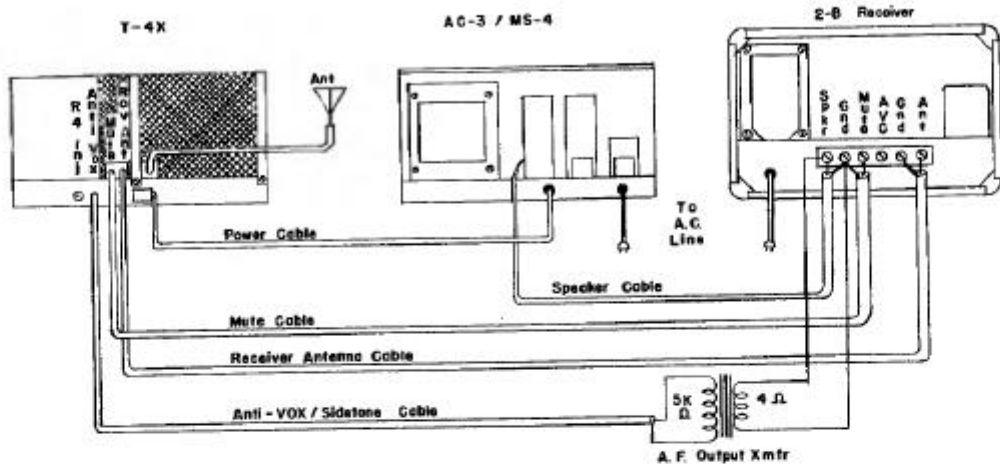

FIG. 3 CONNECTING THE T-4X TO A RECEIVER OTHER THAN THE R-4

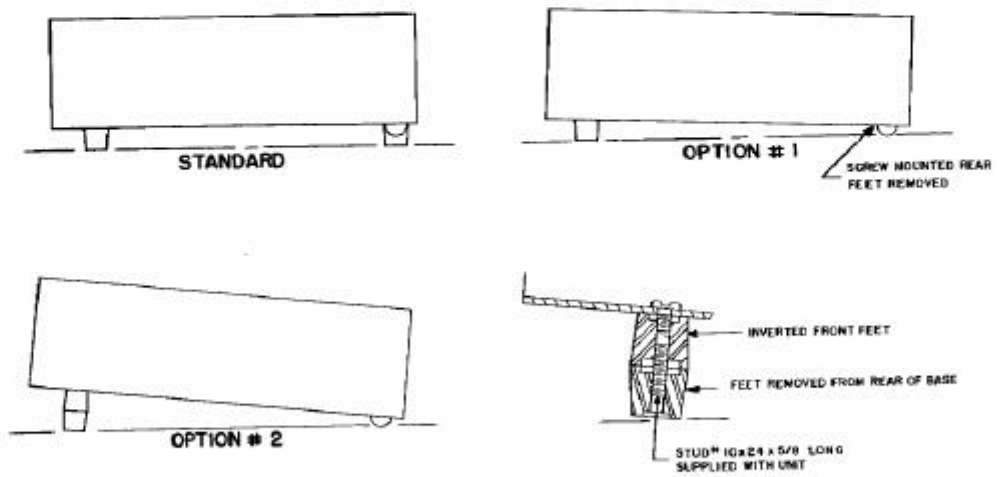

FIG. 4 VIEWING ANGLE OPTIONS

III CONTROL FUNCTIONS

A. T-4X - ONLY (FRONT)

1. **MAIN TUNING** - The MAIN TUNING knob on the T-4X determines the frequency on which you are transmitting or transceiving. The vernier skirt around this knob is calibrated in Kc's from 0 to 25. The main dial is calibrated in five Kc divisions and has two scales. Use the 0 to 500 scale for bands 7.000 - 7.500, 14.000 - 14.500, 21.000 - 21.500, etc.; use the .500 to 1.000 scale for bands 3.500 - 4.000, 28.500 - 29.000, etc. The small red knob just to the right of the dial scale is for adjusting the position of the indicator line for calibrating the main dial. The knob skirt is also adjustable by pushing it in slightly and rotating it in the desired direction while holding the MAIN TUNING knob stationary.

To read your operating frequency on a ham band, add the reading in Kc on the dial skirt to the nearest number on the top scale left of red index line on main dial. Then add megacycles indicated on band switch. On the frequencies off the ham bands the megacycles to be added may be determined by subtracting 11.1 from the crystal in use.

2. **TRANSCEIVE** - The TRANSCEIVE switch determines the frequency controlling VFO when the T-4X is used with the R-4, and is also used for frequency spotting.

In the SPOT position, low level transmitter stages are switched on but the receiver is not muted to allow the transmitter to be tuned to the receiver frequency. This is done without putting a signal on the air.

In the SEPARATE position the T-4X determines the transmit frequency and the R-4 determines the receiving frequency.

In the RCVR position, the R-4 determines both receiving and transmitting frequencies for transceiving. On this mode, the T-4X VFO has no effect.

In the XMTR position, the T-4X determines the receiving and transmitting frequency and the R-4 VFO has no effect.

3. **XTALS** - The XTALS switch is a five position switch used to determine which accessory band crystal socket will be inserted in the circuit. When in the NORM position, band and crystal selection is accomplished by means of the BAND switch (with the exception of the 1.8 - 3.0 setting). When the XTALS switch is set on one of the other positions, 1 through 4, the crystal inserted in the corresponding accessory crystal socket will be inserted in the circuit for that accessory band operation. The BAND switch must then be set in accordance with the information given on the crystal frequency chart for operation on the desired frequency.

B. T-4 & T-4X FRONT CONTROLS & JACKS

1. **PLATE** - The **PLATE** control tunes the power amplifier Pi network circuit to resonance by varying the input capacity.
2. **LOAD** - The **LOAD** control matches the impedance of the transceiver power amplifier to the impedance of the load by varying the output capacity of the Pi network circuit.
3. **METER** - The **METER** reads plate current or relative R.F. output, depending upon the setting of the **METER CONTROL**.
4. **METER CONTROL** - The **METER CONTROL** is a combination spring loaded switch and potentiometer. The meter normally reads P.A. Plate current. When the knob is depressed, the switch converts the meter to read relative R.F. output and when rotated it varies the sensitivity of the relative output indicator. Releasing the control allows it to return to the plate current position.
5. **R.F. TUNE** - The **R. F. TUNE** control permeability tunes the driver grid and plate coils and the premixer output coils. The logging scale on this control is calibrated from 0 to 10 with markings showing the approximate settings for the 160 through 10 meter Amateur bands.
6. **GAIN** - This control regulates the microphone gain on AM and SSB. When the unit is on CW or TUNE, it is used to adjust the R.F. drive to the proper level.

This control is connected so that it regulates VOX sensitivity as well as the audio drive to the balanced modulator. Since all changes in level due to the type mike, how close or loud you talk, etc., effect equally the VOX and the audio drive requirements, this eliminates the necessity of changing the VOX adjust control, located on the side of the chassis, once it is set properly.

Since relay operation on CW depends partially on sidetone voltage fed through the VOX system, the **GAIN** control must be turned up slightly on CW to obtain positive relay action.

7. **SIDEBAND** - This control selects between either of two 2.4 Kc crystal filters for sideband selection. You will notice that lower sideband which is marked with an "X" must be used for CW and AM operation. The **FUNCTION** switch is also marked with an "X" in these positions.
8. **BAND** - The **BAND** control is a six position switch used to select the amateur band desired or to switch the R.F. circuits to the correct tuning range when tuning accessory frequency ranges. The frequency range which may be tuned for each setting of the band switch control is given on the chart on page 23.

9. **FUNCTION** - The **FUNCTION** switch is a four position switch which determines the mode of output. When in the **TUNE** position, a series resistance is inserted in the screen lead of the final amplifier tubes to limit screen current.

WARNING: The **TUNE** position of this switch automatically places the transmitter on the air so consideration should be given to other control settings as described under "Tune up procedure", before turning to **TUNE** to avoid damage to the final amplifier tubes.

10. **MIC** - The **MIC** jack consists of a .210-inch diameter phone jack of the three conductor variety to accommodate microphones with push to talk switches. A mating plug is provided with this equipment. Connections to plug are: Tip-push to talk switch; sleeve-microphone; body-common for both.

C. SIDE CONTROLS AND JACKS (T-4 & T-4X)

1. **VOX** - The **VOX** control is used to adjust the gain of the **VOX** amplifier and relay release time on **CW**.
2. **ANTI VOX/SIDETONE** - Adjusts the **ANTI VOX** sensitivity and sidetone output level.
3. **XTAL (T-4 only)** - A crystal inserted in this socket provides a means for fixed frequency output. (See "Crystal controlled operation").

D. REAR CONNECTIONS

1. **ANT** - Consists of **SO-239** connector for attaching **T-4** or **T-4X** to antenna.
2. **RCVR ANT** - Connects receiver to antenna through built in antenna relay.
3. **RCVR MUTE** - Provides short circuit to ground on receive and open circuit on transmit for muting receiver.
4. **ANTI VOX/SIDETONE** - Serves as **ANTI VOX** input on receive and sidetone output on transmit.
5. **INJ.** - Serves to couple the **T-4** or **T-4X** to the frequency controlling circuits of the **R-4** Receiver if transceive operation is to be used.
6. **KEY JACK** - This normally closed jack provides a means to connect a key for **CW** operation. On other modes the key should be removed or left in key down position.
7. **POWER CONNECTOR** - A 12 connector socket is provided for connection to the **AC-3** or **DC-3** Power Supply. A matching plug is provided on the power supply.

E. INSIDE CONTROLS

1. **CARRIER BALANCE** - The **CARRIER BALANCE** Control is located on top of the chassis, near right rear, and serves to balance the balanced modulator. This is a planetary drive potentiometer requiring 10 turns for complete travel.

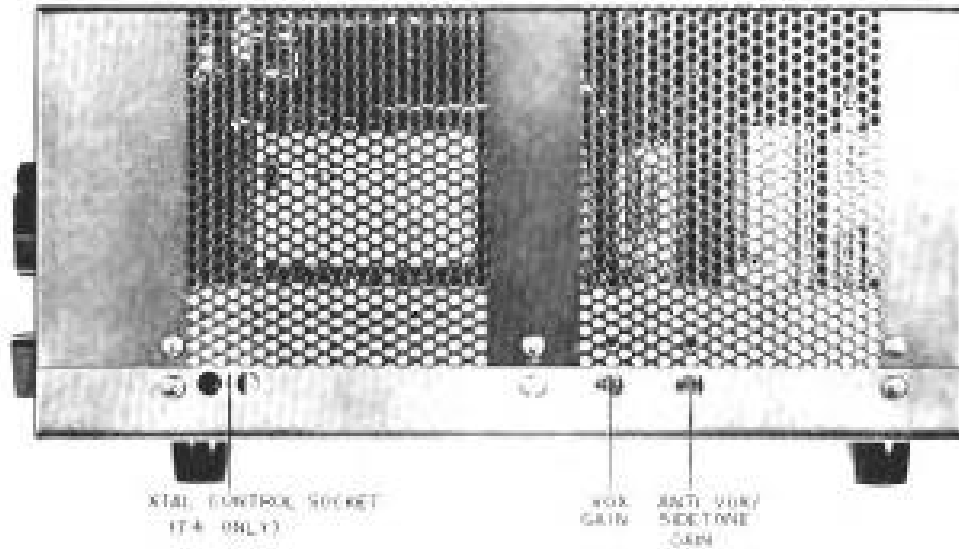

FIGURE 5 SIDE VIEW

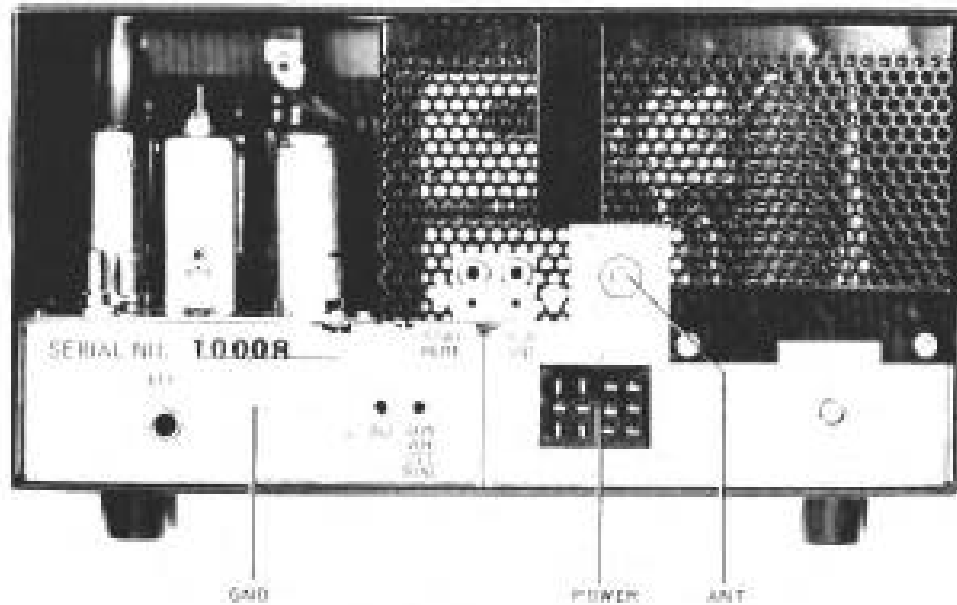

FIGURE 6 REAR VIEW

IV TUNING PROCEDURE

WARNING: UNDER NO CIRCUMSTANCES SHOULD OPERATION OF THE T-4 or T-4X BE ATTEMPTED UNLESS IT IS CONNECTED TO A PROPER ANTENNA OR A DUMMY LOAD OF SUFFICIENT POWER HANDLING CAPACITY.

A. BIAS ADJUSTMENT:

Before any type of operation is attempted, it will be necessary to set the power supply bias to the correct value. Proceed as follows:

1. Turn T-4 or T-4X on by rotating gain control clockwise until click is heard and set gain at minimum (extreme counter clockwise position).
2. Set SIDEBAND switch on upper.
3. Set FUNCTION switch on **TUNE**
4. Adjust AC-3 bias control for a reading of .07 on the plate amperes meter. This is 1-1/2 marks below .1 on meter.
5. Return FUNCTION switch to SSB position. This completes bias adjustment.

B. TUNE UP ON DESIRED BAND:

CAUTION: When tuning, do not allow more than .1 AMP of plate current to exist for more than 30 to 40 seconds at a time. Longer on periods than this may cause the final amplifier tubes to exceed their maximum temperature, thus shortening their life. If a longer tune up period than this is required, give the tubes a rest period of a minute or two to cool off.

Note: Incorrect setting of RF TUNE may cause illegal output from the transmitter on frequencies other than intended. Always preset the RF TUNE control before proceeding with other steps in tune up procedure.

Preset controls as follows:

1. BAND switch to desired band.
2. MAIN TUNING knob to a frequency inside the amateur band in use.
3. XTAL switch on normal.
4. GAIN fully counter clockwise.
5. LOAD fully counter clockwise.
6. SIDEBAND either upper or lower.
7. FUNCTION switch to SSB.
8. RF TUNE to center of band in use.

Rotate the FUNCTION switch to the TUNE position and advance the GAIN control until the plate meter moves up scale slightly from idling current. Peak RF TUNE for maximum plate current while adjusting the GAIN control setting so as to prevent the plate current from exceeding .150. Quickly tune the PLATE control for a dip in plate current. After this dip is found, advance the GAIN control clockwise until the plate current no longer increases.

Depress the OUTPUT METER control and rotate it for a significant indication on the meter. This control converts the plate amperes meter to a relative output indicator and varies its sensitivity.

Alternately adjust the LOAD and PLATE controls for maximum RF output. If the meter reads off scale, simply reduce its sensitivity by turning the OUTPUT METER control counter-clockwise.

When maximum output has been obtained, release the OUTPUT METER control and re-adjust the PLATE control slightly to maintain plate current dip. At this point the meter should read between .25 and .32 amps, depending on line voltage, antenna match and tube condition. Do not attempt to increase the LOAD control beyond the point at which maximum RF output occurs! This will result in excessive plate dissipation which will shorten tube life.

The above tune up procedure should be completed as quickly as possible and the FUNCTION switch returned to the SSB position.

The transmitter is now ready to operate in any mode at the frequency to which it was tuned.

C. CARRIER BALANCE ADJUSTMENT:

The CARRIER BALANCE control is factory adjusted and should require a minimum of re-setting under most conditions. However, it should be checked before the T-4 or T-4X is operated on SSB.

After tuning up as described above, set SIDEBAND switch to "X", GAIN fully counter-clockwise, and FUNCTION switch to CW. Depress the OUTPUT METER control and rotate it clockwise for maximum indication on the meter. Press the push to talk switch on the microphone and adjust CARRIER BALANCE for minimum reading on the output meter. It should be possible to reduce the output to zero. If you cannot, it may be necessary to adjust the carrier balance capacitor (C-6) as described in section VIII. When satisfactory balance is obtained, return the FUNCTION switch to SSB. This completes the adjustment.

D. DIAL CALIBRATION ON THE T-4X:

Due to tolerance limits of the various crystals involved, dial calibration may vary slightly from band to band. For this reason, the MAIN TUNING dial index has been made adjustable by means of the small red knob to its right. To set the calibration on a given band, proceed as follows:

1. Set receiver to a known frequency within an amateur band such as a 100 Kc calibrator point.
2. Tune MAIN TUNING dial of T-4X to same approximate frequency.
3. Set TRANSCIVE switch to SPOT and FUNCTION switch to SSB.
4. Carefully tune the T-4X beat note toward zero beat until a "canary" type sound is heard. Two or three "tweets" per second indicate that the units are tuned to within two or three cycles of each other.
5. Slide red line to the right or left until dial reads correct frequency.
6. While holding main tuning knob stationary, push in on metal skirt and rotate it until it also reads correct frequency.

V OPERATION

In the following discussion concerning operation on various modes, it is assumed that the T-4 or T-4X has already been tuned up on the desired band as described in the tuning procedure.

A. VOICE CONTROLLED AND PUSH TO TALK OPERATION ON SSB:

Preset controls as follows:

SIDEBAND	-- Desired Sideband (usually lower on 80 and 40 and upper on 20, 15 and 10)
FUNCTION SWITCH	-- SSB
GAIN	-- Fully counter-clockwise
VOX GAIN	-- (Forward side control) fully clockwise
ANTI VOX	-- (Rear side control) fully counter-clockwise

The receiver should be operating normally on the same band except that the audio gain control must be turned all the way down.

Talk into the mike at normal voice level and increase the GAIN control until the plate meter kicks to about .15 amps. Reduce the VOX GAIN until a point is reached where the relay drops out too frequently to suit you. Then advance it just enough to prevent this. Increase the receiver audio gain control for normal volume and adjust the ANTI VOX clockwise just high enough to prevent cycling between transmit and receive. The transmitter is now ready for SSB operation.

For push to talk operation, be sure the switch on your microphone is properly connected as described under installation instructions. It may then be depressed at any time, thus overriding the VOX system. The transmitter will remain on and the receiver muted as long as the switch is down. If you do not desire the VOX to function at all, turn the VOX control fully counter-clockwise.

B. CW OPERATION:

Set controls as follows:

SIDEBAND	-- On "X" (lower)
FUNCTION SWITCH	-- X-CW
GAIN	-- Fully counter-clockwise
VOX GAIN	-- Set to mid-range

Plug a key into the KEY jack on chassis rear and leave in key up condition. If an electronic keyer is used, connect it for grid block keying. If the sidetone is to be heard on transmit, the anti vox circuit must be connected as outlined under installation instructions.

To transmit, depress the key and rotate the GAIN control clockwise just below the point at which the plate current no longer increases. Do not advance it beyond this point.

Advance the ANTI VOX/SIDETONE control on the side of the chassis until the sidetone reaches the desired volume.

The T-4 and T-4X use automatic transmit-receive keying. This means that they will automatically transmit when the key is depressed and will remain in the transmit condition through keying at all normal speeds. They will return to the receive condition when the key is released for a brief period. If the "hold in" time is excessive, decrease the setting of the VOX control.

Manual transmit-receive switching can be accomplished by connecting an external switch (i.e. foot switch) from the push to talk terminal of the MIC jack to ground.

C. AM OPERATION:

The T-4 and T-4X use controlled carrier screen modulators for AM. This holds the unmodulated carrier input power to a few watts but allows up to 200 watts P.E.P. input on voice peaks.

1. For AM operation set the FUNCTION switch to X-AM and the SIDEBAND switch to "X".
2. While talking into the mike at normal voice level, increase the GAIN control until the plate meter kicks to a .15 amps on peaks. Care should be taken not to exceed this level as there is no AGC on AM.

If voice control is to be used the VOX and ANTI VOX controls should be adjusted as outlined under SSB operation. If push to talk is to be employed and you do not want the VOX to function at all, turn the VOX control fully counter-clockwise.

D. SPOTTING:

The SPOT position of the TRANSCEIVE switch is used to bring the T-4X to the same frequency as the receiver when separate control is being used. In this position, the receiver is operative but not connected to the antenna. The transmitter final is not operating but the frequency controlling stages are on and output will be heard in the receiver. On SSB set the receiver and the T-4X to the same SIDEBAND. Bring the transmitter to the receiver frequency with the MAIN TUNING dial. A beat note will be heard in the receiver and its pitch will decrease as zero beat is approached. When the two units are near the same frequency, a chirping sound will be heard very much like the sound of a canary. When the "tweets" occur only a few times per second, the transmitter is within a very few cycles of the receiver frequency.

On CW set the receiver and the T-4X for CW operation. A beat note will be heard as the receiver approaches the T-4X frequency. Their frequencies will be the same when the pitch decreases to zero beat. On AM tune the T-4X for maximum receiver S meter reading or set receiver on CW and zero beat.

E. TRANSCEIVING:

When either the T-4 or T-4X is used in conjunction with the R-4 Receiver, transceive operation may be obtained.

IMPORTANT: Only the R-4 Receiver may be employed for this purpose. No earlier model Drake receiver or transceiver or accessory, or that of any other manufacturer will provide the correct injection frequencies.

In the case of the T-4, transceive operation will always be obtained unless it is crystal controlled, (see section G, page 24) since it has no VFO or HF oscillator of its own.

When the T-4X is used, three operating possibilities are available and are selectable by means of the TRANSCEIVE switch on the front panel, as follows:

1. When in the SEPARATE position, the R-4 determines only the receiving frequency and the T-4X determines only the transmitting frequency.
2. When in the RCVR position, the R-4 determines both transmit and receive frequencies. In other words, you will transceive on the frequency to which the R-4 is tuned.
3. When in the XMTR position, the T-4X determines the transceive frequency.

Due to the fact that the accessory crystal sockets are more numerous and more accessible on the R-4, it would be desirable to use the R-4 for transceiving on frequencies outside the amateur bands. If separate receiver transmitter operation is desired on such a frequency, two crystals will be required; one for the T-4X and the other for the R-4.

CAUTION: If transceiving outside the ham bands is to be attempted with the R-4, using either the T-4 or T-4X, the chart on page 21, should be followed closely when choosing crystals to avoid illegal spurious outputs.

When transceiving, several precautions should be observed:

1. Be sure that the T-4 or T-4X is properly connected to the R-4 as illustrated in Figure #1.
2. Both receiver and transmitter must be switched to the same band.
3. Be particularly careful to stay within the confines of the amateur band to be used. This is an easy thing to forget on transceive since your transmitter will be operating on the frequency on which you are listening.
4. Note that band switches, sideband selectors, preselector, and R.F. tune controls on both the receiver and transmitter must always be properly set whether transceive or separate receive and transmit functions are being used.

Choice of whether or not to transceive when the option is available is largely a matter of operator preference. When operating SSB, it has become standard practice for all stations in a contact to be on exactly the same frequency. Transceive is very convenient under these conditions. However, if you are chasing an elusive DX station who does not come into the American Phone Band, separate control is far superior. Or, if your round table is scattered by even a few hundred cycles, it is better to maintain your transmitting frequency and use separate control of the receiver to follow the strays.

On CW, if the note that your ear is trained to prefer differs from that employed by the operator on the other end, transceive may lead you to chase each other up or down the band as each returns to get the pitch he likes. Separate control solves this problem.

F. OPERATION ON ACCESSORY FREQUENCIES:

The design of the T-4 and T-4X transmitters will permit operation of the units on many frequencies outside the ham bands, such as MARS frequencies, etc. Some frequencies where spurious outputs may occur or where sufficient output cannot be obtained, cannot be used. Notable among these are frequencies from 2.3 - 3.0 mc, 5.0 - 6.0 mc, and from 10.5 to 12.0 mc.

No crystal for 160 meter operation is included in the transmitter. If you plan to use this band, you need an additional crystal in one of the auxiliary crystal sockets. The same is true of the 10 meter band from 28.0 - 28.5 mc or above 29.0 mc.

To operate on these frequencies or on any of the frequencies shown in Figure #7 on page 21, a crystal of the frequency listed in this chart must be added either in one of the auxiliary sockets provided in the T-4X or in the R-4 Receiver if a T-4 is used.

In the T-4X, provision is made for plugging in up to 4 additional crystals and the XTAL switch on the front panel provides for selecting the desired crystal.

To tune up on such frequencies, set the XTAL switch to the crystal required, set the BAND switch as indicated in Figure #7 and the RF TUNE control as indicated in Figure #8.

If you plan to transceive, (which you must do with the T-4), the preselector on the R-4 must also be peaked on the correct frequency as indicated on page 19 of the R-4 instruction book.

CAUTION: It is possible to obtain output from the transmitter on the crystal frequency rather than the desired frequency if the RF TUNE control is misadjusted. The settings shown in Figure #8, page 23, should be checked and closely followed when tuning on any accessory frequency.

From this point on, tuning procedure should be the same as described for various modes of operation on the HAM BANDS.

In selecting crystals for operation outside ham bands, Figure #7 should be followed carefully. Use of other crystals may result in illegal output on other frequencies as well as on the desired frequency.

G. RTTY OPERATION:

The T-4 or T-4X is well suited to frequency shift keying as employed in teletype operation. If you contemplate such operation, you are invited to write for special instructions covering the recommended method of shifting the VFO frequency to accomplish this.

Figure #7 CRYSTAL FREQUENCY CHART

CAUTION: USE OF THE T-4 OR T-4X ON FREQUENCIES NOT SHOWN IN THIS TABLE OR WITH CRYSTALS OTHER THAN THOSE SHOWN FOR A PARTICULAR FREQUENCY MAY RESULT IN ILLEGAL SPURIOUS OUTPUT ON FREQUENCIES OTHER THAN INTENDED AND SHOULD BE AVOIDED.

USEABLE FREQUENCY	DO NOT USE BETWEEN	CRYSTAL	OUTPUT FREQUENCY EQUALS DIAL PLUS	BAND SWITCH	RF TUNE
1.8 - 2.0	1.5 - 1.8	12.6	1.5	1.8 - 3.0	0 - 2
1.8 - 2.3		12.9	1.8	1.8 - 3.0	0 - 4
2.3 - 3.0	Do Not Use	None			
3.0 - 3.5		14.1	3.0	3.5	0 - 2
3.5 - 4.0		14.6*	3.5	3.5	2 - 4
4.0 - 4.35	4.35 - 4.45	15.1	4.0	3.5	3.5 - 4.5
4.3 - 4.6	4.6 - 4.7	15.4	4.3	3.5	4 - 5
4.5 - 4.7	4.7 - 4.8	15.6	4.5	3.5	4.5 - 5
4.7 - 4.8	4.6 - 4.7	15.4	4.3	3.5	5 - 5.5
4.8 - 5.0	4.7 - 4.8	15.6	4.5	3.5	5 - 5.5
5.0 - 6.0	Do Not Use	None			
6.0 - 6.5		17.1	6.0	7.0	3.9 - 4.5
6.5 - 7.0		17.6	6.5	7.0	4 - 5
7.0 - 7.5		18.1	7.0	7.0	5 - 5.5
7.5 - 8.0		18.6	7.5	7.0	5.5 - 6
8.0 - 8.5		19.1	8.0	7.0	6 - 6.5
8.5 - 9.0		19.6	8.5	7.0	6.4 - 6.8
9.0 - 9.35	9.35 - 9.5	20.1	9.0	7.0	7.0
9.3 - 9.55	9.55 - 9.7	20.4	9.3	7.0	7.2
9.5 - 9.75	9.75 - 9.9	20.6	9.5	7.0	7.4
9.7 - 9.9	9.9 - 10.0	20.8	9.7	7.0	7.6
9.9 - 10.00	10.0 - 10.15	21.0	9.9	7.0	7.3
10.0 - 10.2	9.9 - 10.0	20.8	9.7	14.0	4.8 - 5.0
10.2 - 10.4	10.0 - 10.20	21.0	9.9	14.0	5.0 - 5.3
10.25 - 10.5	10.1 - 10.25	21.1	10.0	14.0	5.0 - 5.3
10.5 - 12.0	Do Not Use	None			
12.0 - 12.5		23.1	12.0	14.0	6.6
12.5 - 13.0		23.6	12.5	14.0	6.7
13.0 - 13.5		24.1	13.0	14.0	6.8
13.5 - 14.0		24.6	13.5	14.0	7 - 7.2
14.0 - 14.5		25.1*	14.0	14.0	7.2 - 7.5
14.5 - 15.0		25.6	14.5	14.0	7.5 - 7.8
15.0 - 15.5		26.1	15.0	14.0	7.8 - 8.0
15.5 - 16.0		26.6	15.5	14.0	8.0
16.0 - 16.5		27.1	16.0	21.0	7.0
16.5 - 17.0		27.6	16.5	21.0	7.2
17.0 - 17.5		28.1	17.0	21.0	7.4
17.5 - 18.0		28.6	17.5	21.0	7.6

USEABLE FREQUENCY	DO NOT USE BETWEEN	CRYSTAL	OUTPUT FREQUENCY EQUALS DIAL PLUS	BAND SWITCH	RF TUNE
18.0 - 18.5		29.1	18.0	21.0	7.7
18.5 - 19.0		29.6	18.5	21.0	7.8
19.0 - 19.5		30.1	19.0	21.0	8.0
19.5 - 20.0		30.6	19.5	21.0	8.1
20.0 - 20.5		31.1	20.0	21.0	8.3
20.5 - 21.0		31.6	20.5	21.0	8.5
21.0 - 21.5		32.1*	21.0	21.0	8.6
21.5 - 22.0		32.6	21.5	21.0	8.8
22.0 - 22.5		33.1	22.0	21.0	9.0
22.5 - 23.0		33.6	22.5	21.0	9.0
23.0 - 23.5		34.1	23.0	28.5	8.0
23.5 - 24.0		34.6	23.5	28.5	8.2
24.0 - 24.5		35.1	24.0	28.5	8.4
24.5 - 25.0		35.6	24.5	28.5	8.5
25.0 - 25.5		36.1	25.0	28.5	8.5
25.5 - 26.0		36.6	25.5	28.5	8.6
26.0 - 26.5		37.1	26.0	28.5	8.8
26.5 - 27.0		37.6	26.5	28.5	9.0
27.0 - 27.5		38.1	27.0	28.5	9.2
27.5 - 28.0		38.6	27.5	28.5	9.2
28.0 - 28.5		39.1	28.0	28.5	9.4
28.5 - 29.0		39.6*	28.5	28.5	9.5
29.0 - 29.5		40.1	29.0	28.5	9.8
29.5 - 30.0		40.6	29.5	28.5	10.0

NOTE: Crystals can be obtained from the R. L. Drake Company. When ordering, be sure to specify whether the crystal you are ordering is for the T-4X or R-4. They are not the same!

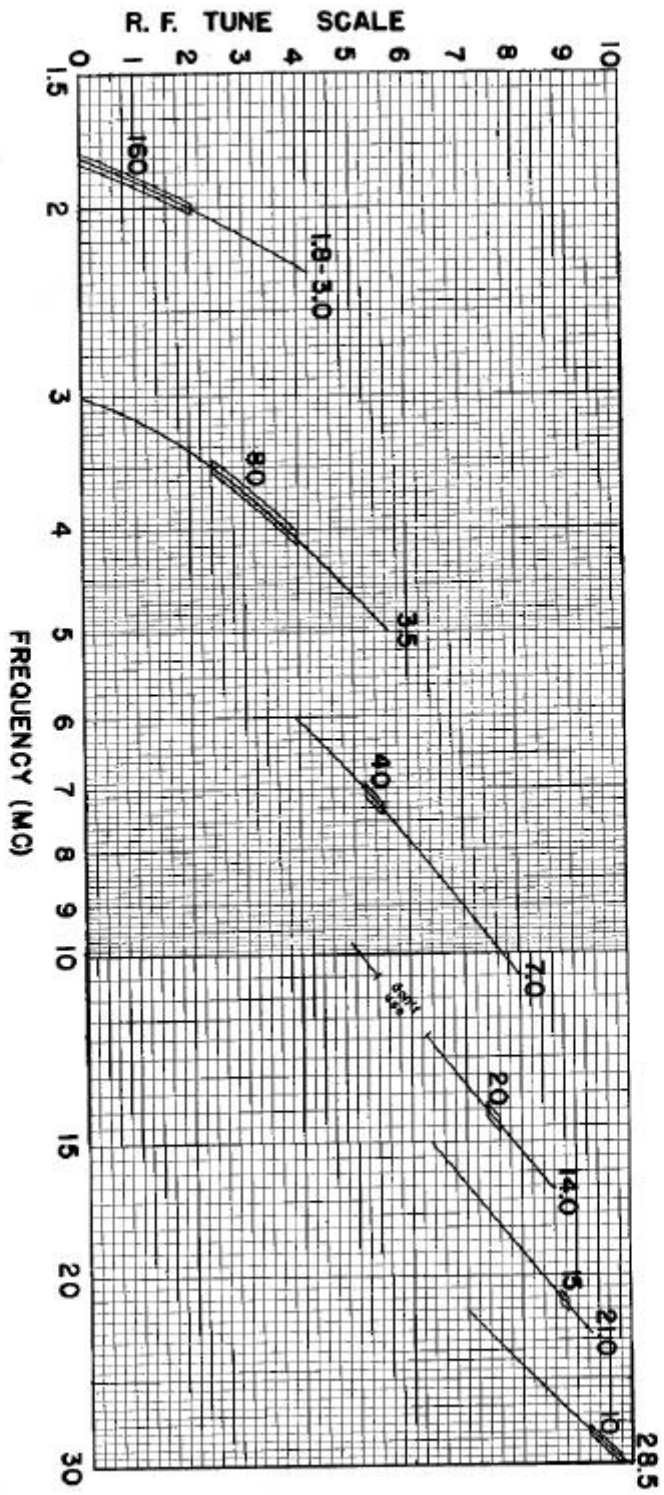

FIGURE 8
R.F. TUNE CALIBRATION CURVES of the useful range for each BAND switch position.

H. CRYSTAL CONTROLLED OPERATION:

The T-4 may also be operated as a crystal controlled transmitter when desired. A socket for this purpose is provided on the side of the chassis.

Crystals for this application should be of the parallel resonant fundamental variety with HC-6/U holders. A trimmer is provided on the T-4 for fine frequency adjustment.

The frequency of the crystal to be used in this socket should be equal to the desired operating frequency + 5645 Kc or to 1/2 of this value if it exceeds 15 mc.

EXAMPLES:

Desired operating frequency 7155 Kc + 5645 Kc = 12,800 Kc (crystal frequency)
or
Desired operating frequency 21,145 Kc + 5645 Kc = 26,790 Kc ÷ 2 = 13,395 Kc
(crystal frequency)

C-124 on the T-4 is connected directly across this crystal socket and if it is desired to bring a crystal exactly to a specific frequency, it can be done by adjusting this trimmer.

To operate on crystal control, plug in the correct crystal and disconnect the cable from the R-4 INJECTION jack on the rear of the T-4 chassis.

All further tune up is exactly the same as described earlier under "Tune Up Procedure".

If used on the novice bands with crystal control, maximum legal input power is 75 watts which occurs when the plate meter reads .115 amps. To realize the most useful output under these conditions, readjustment of the BIAS control is suggested. Follow Bias Adjust Procedure on page 13, but under step 4, set bias for minimum readable plate current. If the transmitter is used both on novice band and by another operator on SSB or AM, the bias must be readjusted to its former value before such operation is attempted.

To load the transmitter for novice operation, preset controls as described under "Tune Up Procedure". Switch FUNCTION switch to TUNE and advance GAIN for a very slight increase in plate current. Tune RF TUNE for a peak in plate current, being careful not to exceed .115 amps, and quickly tune PLATE control for a dip in plate current. Turn GAIN control fully clockwise and adjust LOAD control until plate dip occurs at .115 amps. If plate current dip is higher than this, when LOAD control is set to O, reduce the GAIN for plate reading of .115. Switch to X-CW and set GAIN control for a plate current of .115.

I. OPERATION WITH A LINEAR AMPLIFIER:

The T-4 and T-4X Transmitters have sufficient output power to drive most linear amplifiers. A triode type grounded grid linear will usually present a satisfactory load (approximately 50 ohms) for the T-4 and T-4X.

If your linear is of the grounded cathode type with high input impedance, it will be necessary to install a resistive pad between the transmitter and the linear that will present the proper impedance. Such a pad must be made of noninductive resistors and must have adequate power handling capacity to prevent its being destroyed when the transmitter is turned on.

Antenna switching should be accomplished as shown in Figure #2. Many linear amplifiers have these relays built in.

Before operating the T-4 or T-4X with a linear amplifier the instruction manual of the linear should be consulted. The instructions contained here are of necessity generalized and precedence should be given to any specific precautions in the instructions accompanying the linear amplifier since it is improbable that these could lead to any danger to the exciter.

To load the transmitters into a linear, preset controls as follows:

SIDEBAND	-- Lower
GAIN	-- Counter-clockwise
BAND SWITCH	-- Desired band
R.F. TUNE	-- Desired band
LOAD	-- Zero

Turn FUNCTION switch to TUNE and advance GAIN control until plate meter moves up scale slightly from idling current. Peak RF TUNE, being careful not to exceed .150 amps plate current and tune PLATE control for dip in plate current. Set LOAD control as indicated in accompanying table. Redip PLATE control and tune linear as described in the linear amplifier instructions.

Now turn FUNCTION switch to desired mode of operation and advance GAIN control until desired amount of input to the linear amplifier is obtained.

<u>BAND</u>	<u>LOAD</u>
160	2.5
80	3.5
40	4.5
20	4.5
15	4.5
10	4.5

VI THEORY OF OPERATION

The signal which is transmitted by your T-4 or T-4X is the result of mixing three separate oscillators and the audio signals from the mike as well in the case of AM or SSB. In going through the theory of operation, we will use a SSB signal as the basic example and then point out the difference employed in generating an AM or CW signal. Most of the following explanation applies equally to both the T-4 and T-4X. Difference between the two units will be noted as the discussion proceeds.

The signal on single sideband begins in a crystal controlled oscillator V-1A running at 5645 Kc on all bands. Output from this tube is fed to a four diode balanced modulator through the carrier balance control R-4.

The audio signal from the mike is amplified by V-9. Note that half of the GAIN control R-84 appears in the grid circuit of the second half of this tube and serves to control its output.

Two different audio outputs are taken from V-9B. Low impedance output from the cathode is applied to the balanced mixer through the FUNCTION switch for SSB operation. High impedance output is taken from the plate and goes to the grid of V-11 for screen modulation of AM. It is also fed to the VOX amplifier V-10A through the VOX Adjust control R-89. The output from V-10A is rectified and thus supplies positive DC voltage which is applied to the grid of the relay control tube V-10B, causing it to conduct and close the transmit relay. Audio voltage from your receiver reaches the transmitter through the anti vox cable and is rectified by D-9. The resulting negative voltage is applied to the grid of V-10B, so that audio from the speaker picked up by the mike will not cause the relay to close.

For push to talk operation, the negative bias on V-9B is shorted to ground, thus causing the tube to conduct and close the relay and hold it in as long as the push to talk switch is closed.

Returning to the balanced modulator, the audio and 5645 Kc RF inputs combine to produce an output of double sideband suppressed carrier. This is amplified through V-2 and, after impedance transformation in T-2, is applied to either the upper or lower crystal filter where the undesired sideband is filtered out. The resulting SSB signal is fed through T-3 to the mixer stage V-3.

The second input for this mixer is supplied by the pre-mixer stage but its origin is different in the T-4X and the T-4.

In the T-4X the permeability tuned VFO Q-2, controlled by the main tuning dial, oscillates on frequencies from 4955 - 5455 Kc. Output from this stage goes to the pre-mixer through buffer stage Q-1.

Another transistor oscillator (Q-3) is crystal controlled and runs at frequencies 11.1 mc above the low edge of the band in use.

In the pre-mixer stage V-8, the output of the high frequency crystal oscillator and the VFO are combined and the difference frequency is taken from the plate through T-4 and T-5 and fed to the mixer V-3.

In the T-4 the VFO and the high frequency crystal oscillator have been omitted. This injection voltage is supplied from the companion R-4 Receiver and is fed into the pre-mixer stage to be amplified and thence through T-4 and T-5 to the mixer V-3.

Note that when the T-4X is being used to transceive, the receiver may also be used as the frequency control with the injection voltage being supplied from the receiver exactly as in the T-4. Or, if desired, the T-4X may supply the injection voltage through the same cable to control the receiver.

Returning to the mixer, V-3, we have a 5645 Kc single sideband signal being supplied to the control grid from the filter, and high frequency injection from T-5 to the same grid. The plate of this tube is tuned to the difference of these two signals by T-6. It then goes to the driver stage V-4 where it is amplified and applied to the parallel grids of the 6JB6's, V-5 and V-6 through the tuned circuit of T-7.

These tubes serve as linear amplifiers and raise the signal to a suitable power level for transmission. The output is matched to a 52 ohm load by means of the Pi network consisting of C-62, L-9, L-10, and C-70.

The two injection frequency transformers, T-4 and T-5, and the two driver transformers T-6 and T-7 are all permeability tuned by the RF TUNE control which positions their slugs in such a manner that the correct relationship between injection and output frequency is maintained. The injection frequency is always 5645 Kc higher than the transmitted frequency.

In order to minimize flat topping in the final stage if too much signal is provided by the driver, a transmitting AGC circuit is included. At the first trace of overdrive, grid current will be drawn which produces a voltage drop across R-79. The small negative going voltage thus obtained is applied to the cathode of V-1b where it is amplified. It is then applied to the grid of V-2, thus reducing the driving signal.

The meter of the T-4 and T-4X normally reads final amplifier plate current. It is connected in the cathode lead of these tubes.

When the METER control on the front panel is depressed, the meter is connected as an RF output meter through R-37 and D-5. This circuit samples the output voltage at the antenna and rectifies it. R-37 is made variable to control the sensitivity of this circuit in order that it may be used both with full power output and with very little power output when checking carrier balance.

In the CW mode, the 5645 Kc oscillator is shifted slightly in order to put the carrier within the passband of the "lower" crystal filter. A DC voltage is applied to the balanced mixer, thus unbalancing it. The amount of DC voltage and thus the amount of RF output is determined by the setting of the GAIN control. The signal then proceeds through the unit as it does on SSB.

Grid block keying of the mixer V-3 and driver V-4 is used. The sidetone oscillator utilizes the first audio stage V-9 as a phase shift oscillator to produce an audio signal for monitoring. When the key is down, this signal is fed to the receiver audio output transformer through the anti vox cable using V-9B and V-11 as amplifiers. When the key is up D-8 shorts this signal to ground due to the fact that keying is also applied to it.

To trip the transmit receive relay instantly when the key is closed, a pulse generated by D-7 and C-134 is applied to the grid of the relay control tube V-10. During keying the relay will remain in the transmit position since keyed sidetone output is applied to the VOX system.

On AM the carrier oscillator V-1 is again shifted into the passband of the lower side-band filter. A DC voltage applied through R-76 is used to unbalance the balanced modulator.

Audio from the mike amplifier is supplied to V-11 which provides modulation to the screen of the driver stage V-4. The resulting output signal is controlled carrier screen modulated AM. Note that the AGC circuitry does not function when the transmitter is on AM.

VOX and push to talk functions are identical on AM with those described for SSB.

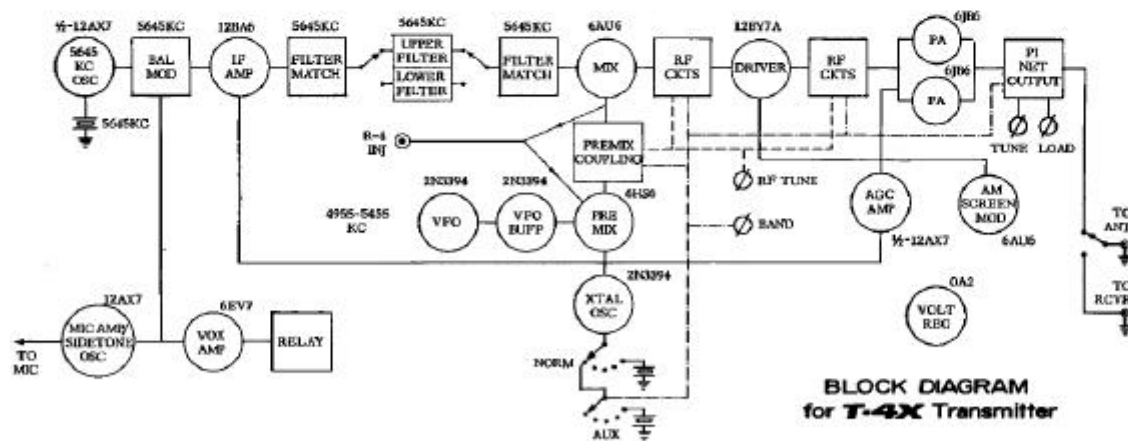

FIGURE 9

VII SERVICE DATA

We will check and factory align your T-4 and T-4X for a nominal fee of \$10.00 plus transportation charges if the set has not been tampered with. If repairs are necessary, an additional charge will be made. Units that have been tampered with or misaligned will be repaired on a time and material basis only.

A. REMOVING TOP COVER:

WARNING: Extreme caution should be taken when the top and bottom covers of the T-4 or T-4X are removed. High voltage is present at several points which could cause a lethal electrical shock!!

1. Remove the three top screws on each side of the T-4 or T-4X.
2. Remove cover by first pulling up on the rear and then on the front of the cabinet.

B. REMOVING BOTTOM COVER:

1. Remove the six bottom screws from the sides of the T-4 or T-4X.
2. Lift T-4 or T-4X chassis out of bottom cover.

C. TUBE REPLACEMENT:

In general, most trouble in radio equipment of good design is due to tube failure. The best method of finding defective tubes is by direct substitution. It is best not to rely too heavily on tube checkers.

The T-4 and T-4X have been designed so that, with the exception of V-5 and V-6, tubes can be replaced without need for realignment. When these tubes are replaced, realignment will only be necessary if a different brand is used than originally supplied. If this is the case, the driver plate circuit will require realignment. See section A under alignment procedure.

To replace the 6JB6 tubes, it will be necessary to remove the final amplifier cage. To do this, remove the insulated shaft couplings from the PLATE and LOAD capacitors, remove the sheet metal screws holding the cage to the chassis, and lift off the cage. To replace the cage, simply reverse the process. Be sure that the parasitic suppressors do not short to the cage.

D. TROUBLESHOOTING:

Careful consideration has been given in the design of the T-4 and T-4X to keep the maintenance problems to a minimum. However, it is quite possible that some problem will arise which cannot be cured by tube substitution. If this occurs, we suggest that you either return your unit to your dealer, or write direct to our Service Department describing your problem in detail. Include full information concerning external connections, control settings, tubes substituted, etc. Do not return equipment to the factory without prior authorization.

In case of malfunction, first check power supply fuse and filament fuse in the T-4 or T-4X for continuity. The voltage and resistance charts which follow should be valuable in isolating minor problems. However, no attempt should be made to service the T-4 or T-4X unless you are thoroughly familiar with electronic circuitry and servicing technique. CARE SHOULD BE TAKEN NOT TO DISTURB THE LEAD DRESS IN THE T-4 AND T-4X SINCE SEVERAL CIRCUITS ARE QUITE CRITICAL IN THIS REGARD.

Figure #10 RESISTANCE CHART

Number	Type	1	2	3	4	5	6	7	8	9
V-1	12AX7	12K	220K	3.3K	Fil	0	0	10K	28K	NC
V-2	12BA6	1 meg	0	0	Fil	15K	30K	47K		
V-3	6AU6	330K	0	0	Fil	14K	43K	15.5 K		
V-4	12BY7	150	68K	0	Fil	0	NC	14K	45K	0
V-5	6JB6	14K	33K	54K	0	Fil	33K	14K	0	54K
V-6	6JB6	14K	33K	54K	Fil	Fil	33K	14K	0	54K
V-7	OA2	11K	NC	NC	NC	NC	NC	9*		
V-8	6HS6	330K	0	0	Fil	14K	90K	470		
V-9	12AX7	360K	3.3 meg	0	Fil	0	280K	500K	3.3K	0
V-10	6EV7	100K	500K	820	Fil	0	18K	4 meg	0	0
V-11	6AU6	22 meg	0	Fil	0	47K	30K	0		

Notes:

1. All measurements were made from ground with transmitter connected to AC-3 power supply and with power supply disconnected from AC line.
2. Controls were set as follows: BAND - 7.0; FUNCTION - TUNE; GAIN, VOX, and ANTI VOX controls all fully clockwise. The position of other controls is unimportant.
3. * This resistance will vary widely on various ohmmeter ranges due to the characteristics of diode D-9.

Figure #11 VOLTAGE CHART

Number	Type	1	2	3	4	5	6	7	8	9
V-1	12AX7	150	2.8	4.2	6.3*	0	0	-62	-62	
V-2	12BA6	0	0	0	6.3*	250	60	2.8		
V-3	6AU6	0	0	0	6.3*	240	142	2.35		
V-4	12BY7	3.5	0	0	6.3*	0	0	250	210	0
V-5	6JB6	250	-62	.9	0	6.3	-62	250	0	.3
V-6	6JB6	250	-62	.9	6.3*	12.6*	-62	250	0	.3
V-7	OA2	150	N.C.	N.C.	N.C.	N.C.	N.C.	.5		
V-8	6HS6	.7	0	0	6.3*	250	130	3		
V-9	12AX7	124	-.9	0	6.3*	6.3*	150	0	1.4	0
V-10	6EV7	100	0	1.3	6.3*	0	200	-.8	0	0
V-11	6AU6	-1.0	2	6.3*	0	25	110	0		

Notes:

1. All measurements were made from ground with an 11 megohm VTVM.
2. Unit was tuned into dummy load on 40 meters as described in "TUNING PROCEDURE", GAIN control was reduced to minimum, and FUNCTION switch is left on TUNE.
3. The AC-3 power supply was used.
4. An * indicates AC voltage.

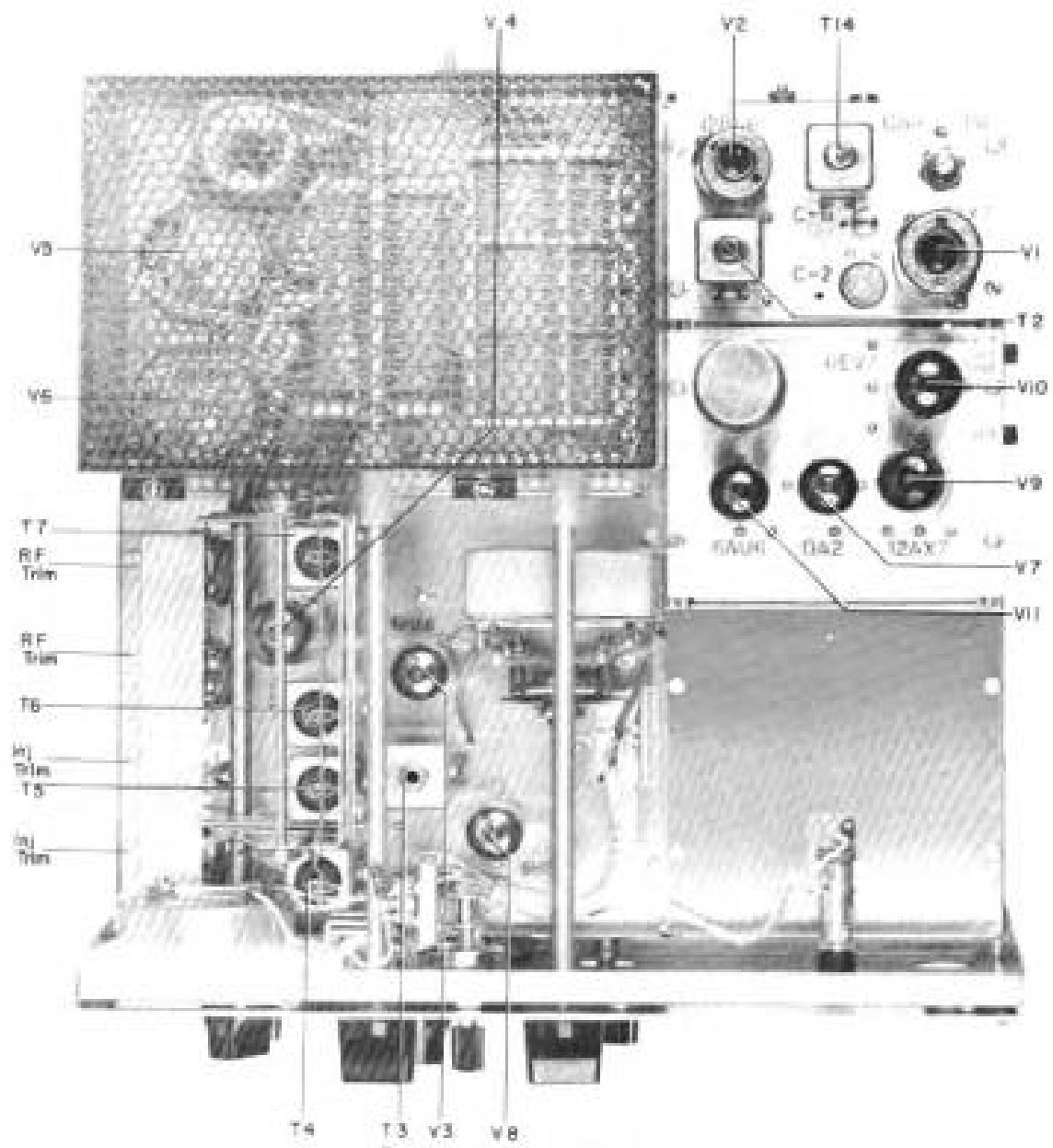

FIGURE 12 TOP VIEW T-4

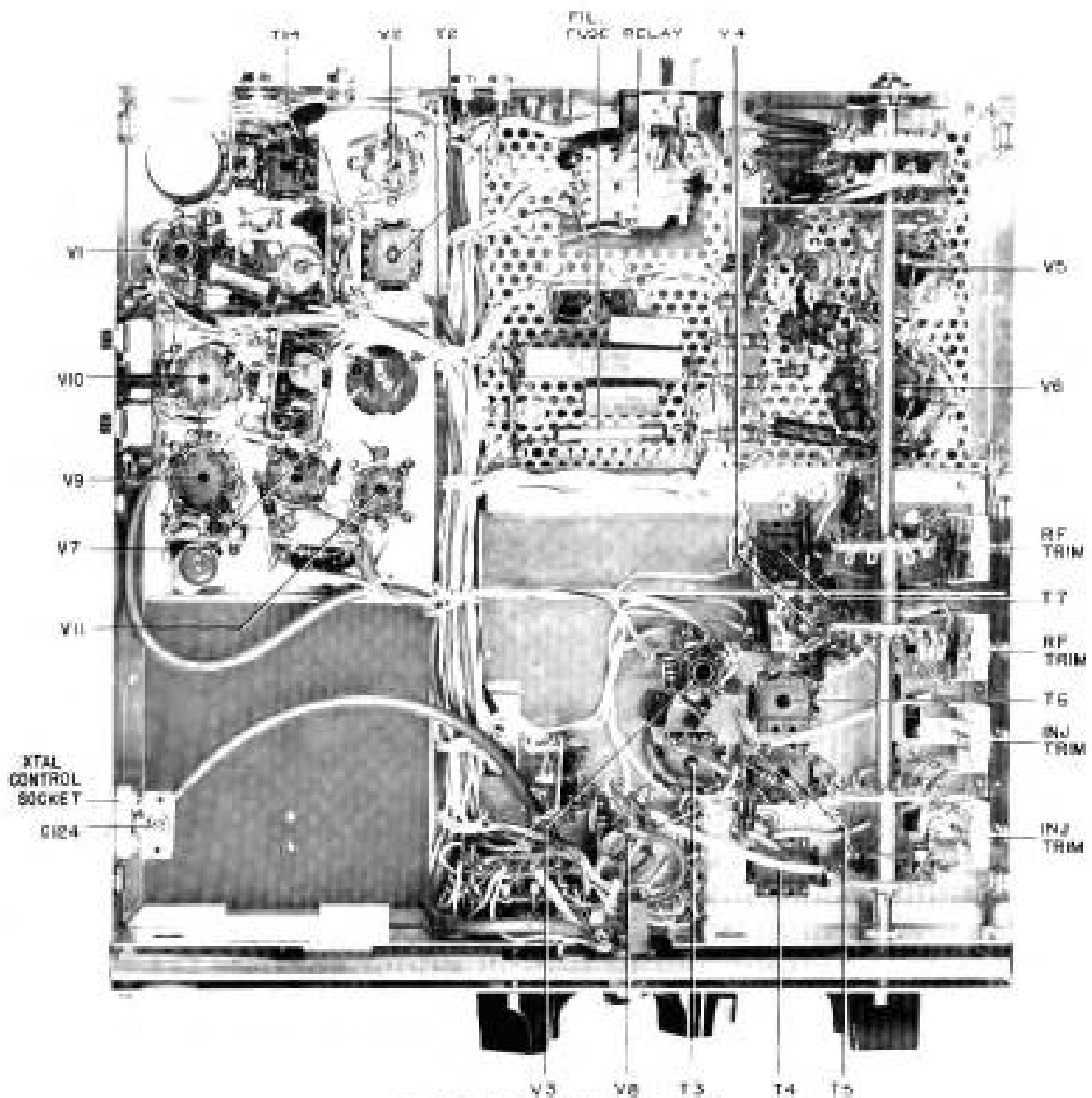

FIGURE 13 BOTTOM VIEW T-4

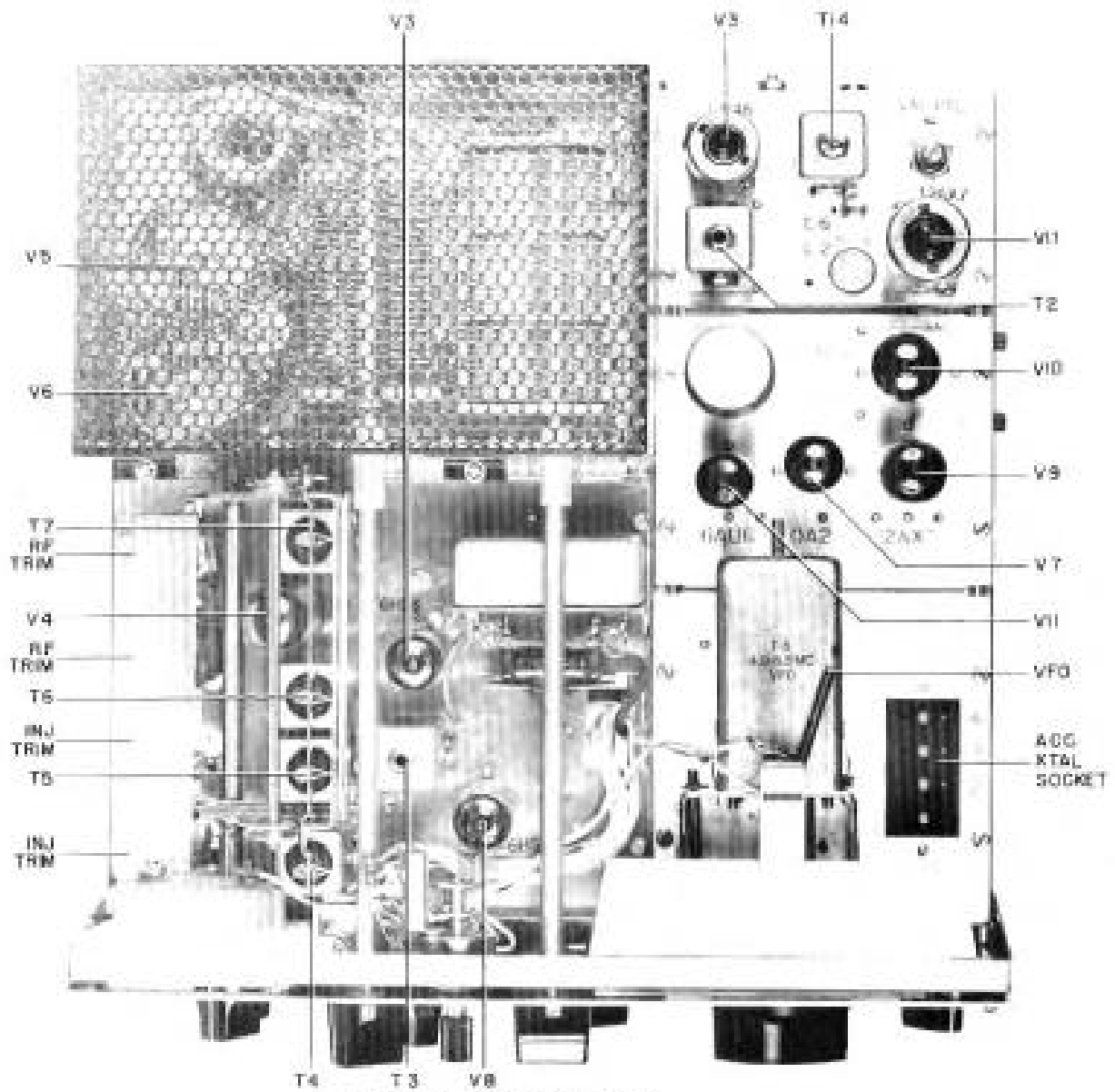

FIGURE 14 TOP VIEW T-4X.

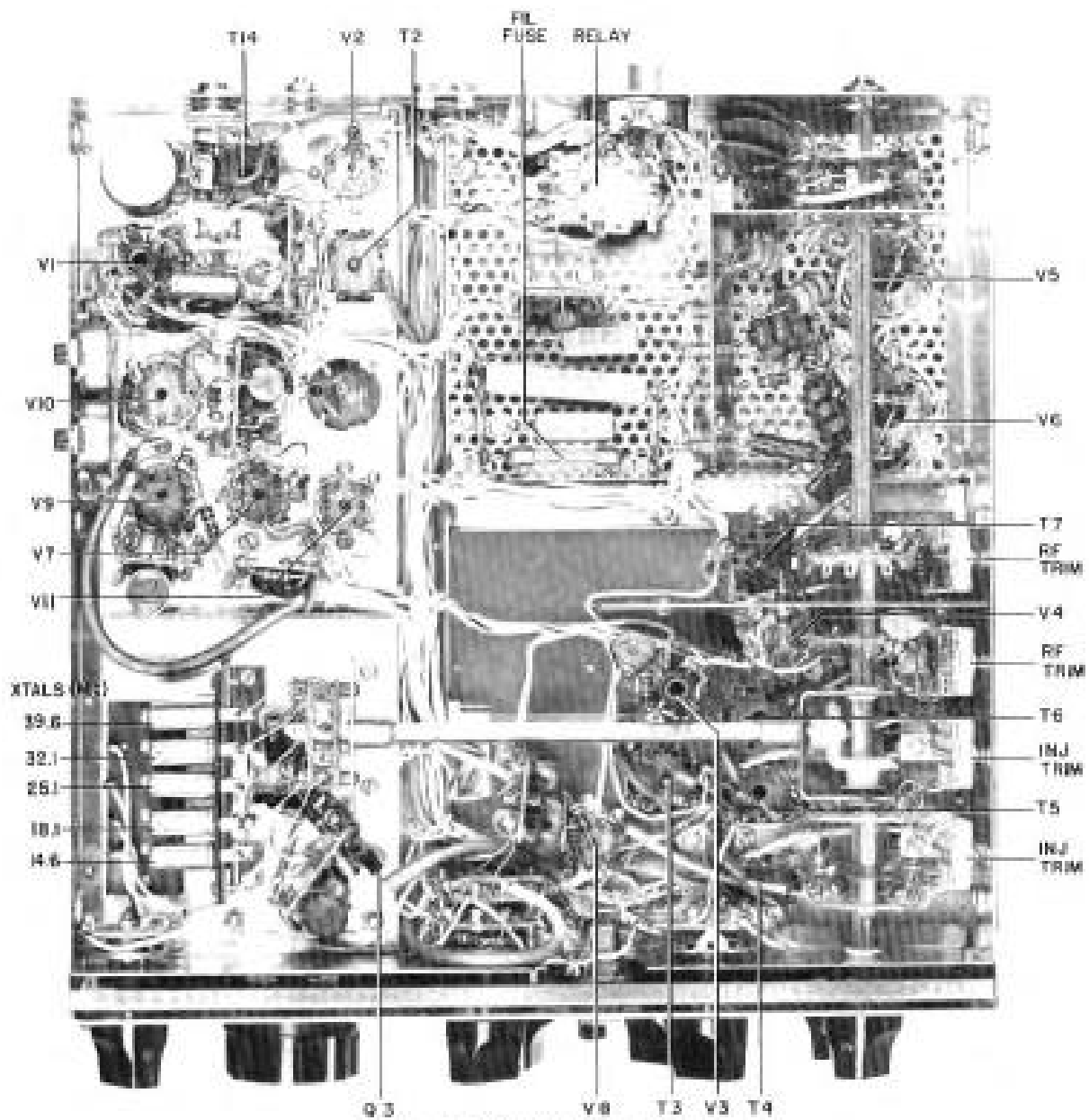

FIGURE 15 BOTTOM VIEW T-4X

VIII ALIGNMENT INSTRUCTIONS

Alignment of the T-4 and T-4X will require the following equipment:

1. Accurate signal generator.
2. An 11 megohm VTVM with RF probe.
3. A 52 ohm dummy load of sufficient power handling capacity. (Heathkit Cantenna).
4. The T-4 and T-4X have built in RF output indicators which can be used. However, an external indicator would be much more convenient.
5. A 12.6 mc xtal for R-4 or T-4X if 1.8 - 3.0 mc range is to be aligned.

WARNING: Do not attempt to operate the transmitter without connecting to a dummy load or serious damage may result.

A. ADJUSTMENT OF RF AND MIXER STAGES:

1. Set the RF TUNE knob to its stop at the extreme clockwise position and carefully measure the length of the slugs above the top of the coil form on T-4, T-5, T-6 and T-7. All should measure exactly 9/16". If necessary, adjust slugs to these settings. (This was done at the factory and should be correct. Check measurements carefully before altering the position of any of these slugs.)
2. With the RF TUNE knob still against the clockwise stop, note the distance between the pointer and the 10 calibration mark. This space should be the same as that between the 0 calibration mark and the pointer at the counter-clockwise stop. If the two spaces are not the same, loosen the knob set screw and position the knob correctly.
3. Disconnect the R-4 injection cable from T-4 or T-4X and in the case of the T-4X, set the FUNCTION switch to RCVR.
4. Connect RF probe of VTVM to the terminal of T-3 to which a 1.5 K resistor, 100 pf capacitor, and .001 mfd capacitor are connected.
5. Connect signal generator to INJ. jack.
6. Turn on T-4, leave GAIN set at minimum, and set FUNCTION switch to SSB.
7. Set the BAND switch to 1.8 - 3.0, set the RF TUNE knob to 1.75 on its scale, and set the generator to 7.6 mc with approximately 1 volt output.
8. Adjust the two 1.8 - 3.0 mc injection trimmer capacitors for maximum indication on the VTVM. The injection trimmers are those in the front two columns on the left side of the chassis.
9. Repeat this procedure on all bands using generator and RF TUNE settings as follows:

<u>BAND</u>	<u>GENERATOR</u>	<u>RF TUNE</u>
1.8 - 3.0	7.6 mc	2.0
3.5	9.3 mc	3.0
7.0	12.8 mc	5.5
14.0	19.6 mc	7.5
21.0	27.1 mc	8.75
28.5	34.5 mc	9.25

10. Turn off transmitter and disconnect VTVM and generator.
- 11a. (T-4X only) Insert a 12.6 mc crystal in one of the four accessory crystal sockets and set the XTAL switch to the number corresponding to that socket for alignment on the 1.8 - 3.0 mc band only. On all other bands, the XTAL switch should be returned to the NORM position. The TRANSCEIVE switch should be left in the SEPARATE position throughout the alignment procedure. Whether or not the R-4 injection cable is reconnected is unimportant.
- 11b. (T-4 only) Connect the R-4 injection cable to the INJ. jack. Insert a 12.6 mc crystal in one of the R-4 accessory crystal sockets and turn the R-4 XTAL switch to the corresponding number when aligning the 1.8 - 3.0 mc band only. On all other bands, return the switch to the NORM position. On all bands the R-4 and T-4 BAND switches should always be on the same position and the R-4 PRESELECTOR should be peaked on noise on each amateur band before T-4 alignment is begun. Throughout the alignment procedure, it will be assumed that these steps have been taken for each new band aligned.
12. (Both T-4 and T-4X) Set BAND switch to 1.8 - 3.0, set the RF TUNE to 2, and set the VFO to 1.985 mc.
13. Preset other controls as follows:

FUNCTION	-- SSB
SIDEBAND	-- Upper or lower
GAIN	-- Minimum (power on)
PLATE	-- 0
LOAD	-- 0

14. Turn FUNCTION switch to TUNE, advance GAIN for noticeable increase in plate current, and adjust PLATE for dip in plate current. Now increase GAIN to maximum and alternately adjust PLATE and LOAD controls for maximum RF output.
15. Reduce the drive until plate current is approximately .1 amps and adjust the two 1.8 - 3.0 mc RF trimmer capacitors for maximum RF output while at the same time adjusting the GAIN to keep the plate current at about .200 amps.

IMPORTANT: The .2 amp figure given in step 15 is an arbitrarily chosen value designed to prevent the drive from saturating the final amplifier during the alignment procedure. If saturation occurs a false indication and apparent broadness when tuning the various adjustments may be observed.

The RF capacitors are in the two columns nearest the rear of the chassis, along the left side.

16. Now detune T-5 by touching the rotor contact of S-4b (the second band switch waffer from the front) with a 6" screw driver with an INSULATED HANDLE, and tune the front 1.8 - 3.0 mc injection trimmer for maximum RF output. Once again care should be taken to prevent the power amplifier from saturating.
17. Detune T-4 by touching the screw driver to the rotor contact of S-4a (the front band switch waffer) and tune the rear injection trimmer for maximum RF output. Keep in mind that the injection trimmers are those in the first two columns.

WARNING: The rotor of S-4a is connected to +250 volts! Use extreme caution.

18. Repeat steps 13 through 17 for each amateur band, using the settings given below:

<u>BAND</u>	<u>RF TUNE</u>	<u>VFO</u>
1.8 - 3.0	2	1.950 mc
3.5	3	3.725 mc
7.0	5.5	7200 KC
14.0	7.5	14.0 mc for RF 14.2 mc for INJ.
21.0	8.75	21.5 mc
28.5	9.25	28.9 mc

You will note that the VFO setting is changed from 14.0 to 14.2 mc for steps 16 and 17 when aligning the 14.0 mc band. Plate tuning should be redipped.

19. Return FUNCTION switch to SSB.

B. CARRIER OSCILLATOR, FILTER MATCH AND BALANCED MODULATOR:

1. Follow regular tune up procedure on any ham band. Turn FUNCTION switch to SSB and depress push to talk switch or short push to talk line to ground at mike jack.
2. Adjust CARRIER BALANCE control on top of chassis for increase in plate current.
3. Switch SIDEBAND switch back and forth noting the difference in plate current or relative output on the two sidebands.
4. Adjust C-2 to make the current or output of the sidebands equal. When such a balance is achieved the carrier is correctly positioned between the upper and lower sideband filters.
5. Now switch to upper sideband and tune filter match cans T-2 and T-3 for maximum plate current or output.
6. Recheck C-2 adjustment after T-2 and T-3 have been tuned. If necessary, repeat step 4 and 5 until all conditions are satisfied.
7. Tune balanced modulator (T-14) for maximum plate current.
8. Rebalance carrier as described under "Tune Up Procedure".

C. NEUTRALIZING FINAL AMPLIFIERS:

1. Set BAND switch to 28.5 and MAIN TUNING dial to .800. Follow standard tune up procedure while loading into 52 dummy load.
2. Depress output meter switch. Note meter reading and turn up meter sensitivity till meter reads well up scale. Then back off GAIN control until approximately 2/3 of maximum output is obtained.
3. Very carefully adjust plate control so that you are exactly on the dip in plate current. Depress output meter switch, observe reading. Tune plate capacitor clockwise slightly to see if there is a rise in output. Return to exact plate current dip and again depress output meter and tune plate capacitor counter-clockwise slightly, looking for a rise in output meter indication.
4. If there was no rise in output in either direction, the transmitter is properly neutralized. If the output did rise on either side of the dip, the set needs neutralizing. Adjust C-40 in small steps repeating step 3 after each adjustment until maximum output and plate current dip exactly coincide. (The adjustment screw for C-40 is accessible in the power amplifier compartment beneath the chassis. See top view.)

D. CRYSTAL OSCILLATOR CHECK:

1. In order to tell whether or not the crystal oscillator is operative on a particular crystal in the T-4X, first locate the 6HS6 pre-mixer (V-8) and temporarily short the cathode (pin 7) to ground.
2. Then measure the voltage on the grid (pin 1) with the DC probe of an 11 megohm VTVM, through a 1 megohm series resistor on end of probe.
3. If the oscillator is operating properly a voltage of from -2 to -3 volts should be observed.

NOTE: C-97, Trimmer on the crystal oscillator is factory set to give best over all performance on all crystals and should not be tampered with. If it is adjusted to improve any one crystal, it may cause other crystals to fail to oscillate.

E. T-4X VFO ADJUSTMENT:

The permeability tuned VFO was carefully adjusted at the factory and should require no further alignment. If it does not appear to track from one end of its range to the other, it should be returned to our plant for realignment. Maximum calibration error is 1 KC when calibrated to the nearest 100 KC point.

If you notice the same error from one end of the band to the other, and you cannot correct it with the movable dial index, the main dial may be slipped on its shaft enough to bring the corrector back into range.

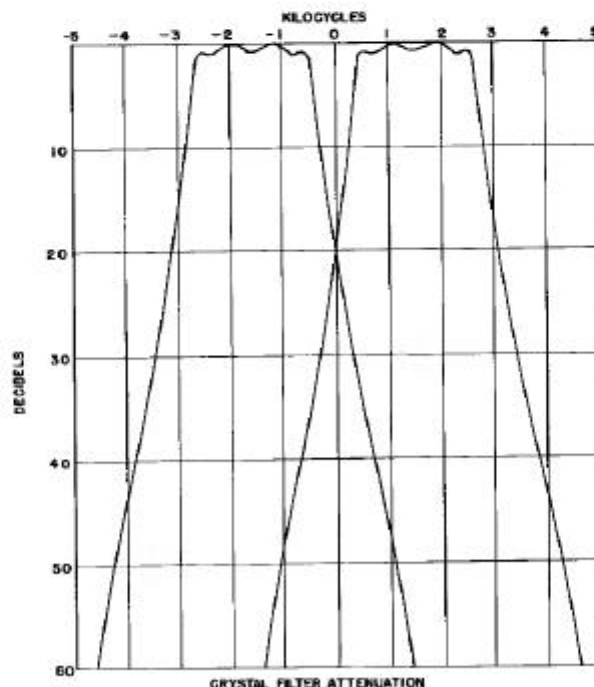

Fig. 16

IX AC-3 POWER SUPPLY

The R. L. Drake Model AC-3 is a complete power supply capable of supplying all of the required voltages for the T-4 and T-4X with the proper filtering and regulation from 120/240 VAC, 50/60 cycles.

It is designed to fit into our Model MS-4 Matching Speaker to become a single unit.

To mount it in this unit, remove the four rubber feet from the bottom and slide it in from the rear so that the line cord and power cable face outward. Fasten it in place with the four screws which were used to hold the feet on.

To connect it to the T-4 or T-4X, simply plug the female power connector on the end of the power cable into the male connector on the rear of the T-4 or T-4X (see T-4 and T-4X installation instructions).

The bias adjustment should be set properly before any operation is attempted. (See T-4 and T-4X tune up instructions.) A test point is provided for ease in measuring final amplifier plate current. This current in amperes is equal to the voltage at this point times 0.2. To properly set the bias voltage for .066 amperes idling current in the T-4 or T-4X, the voltage at this point should read .335 volts.

IMPORTANT: Never ship the AC-3 mounted inside the MS-4 case or serious damage of the case will result.

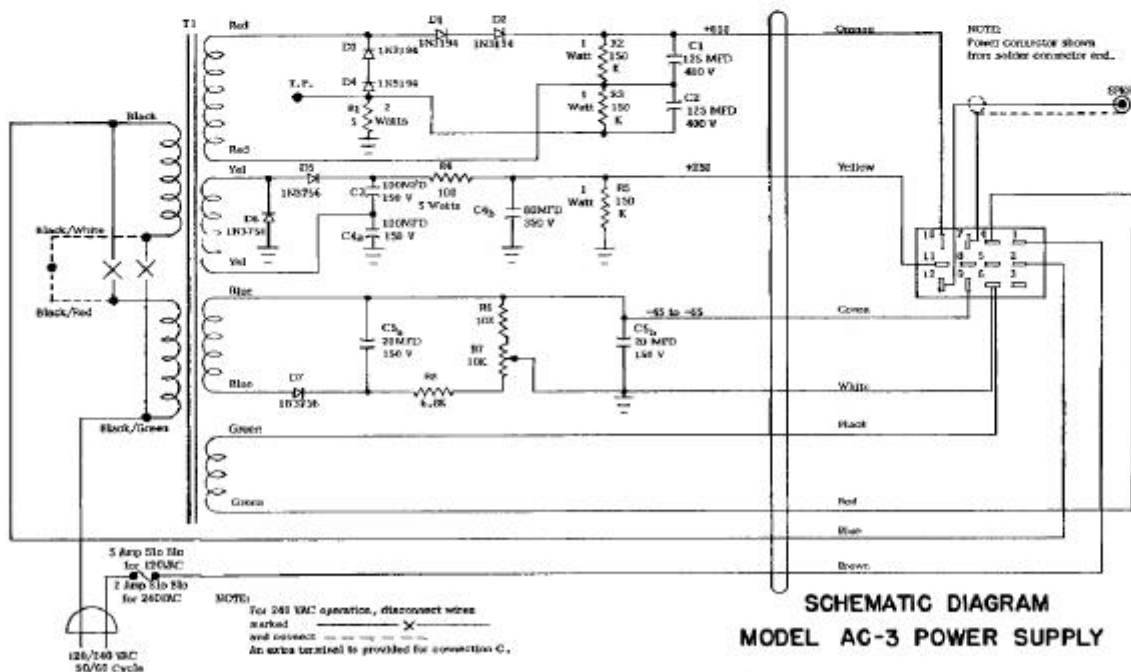
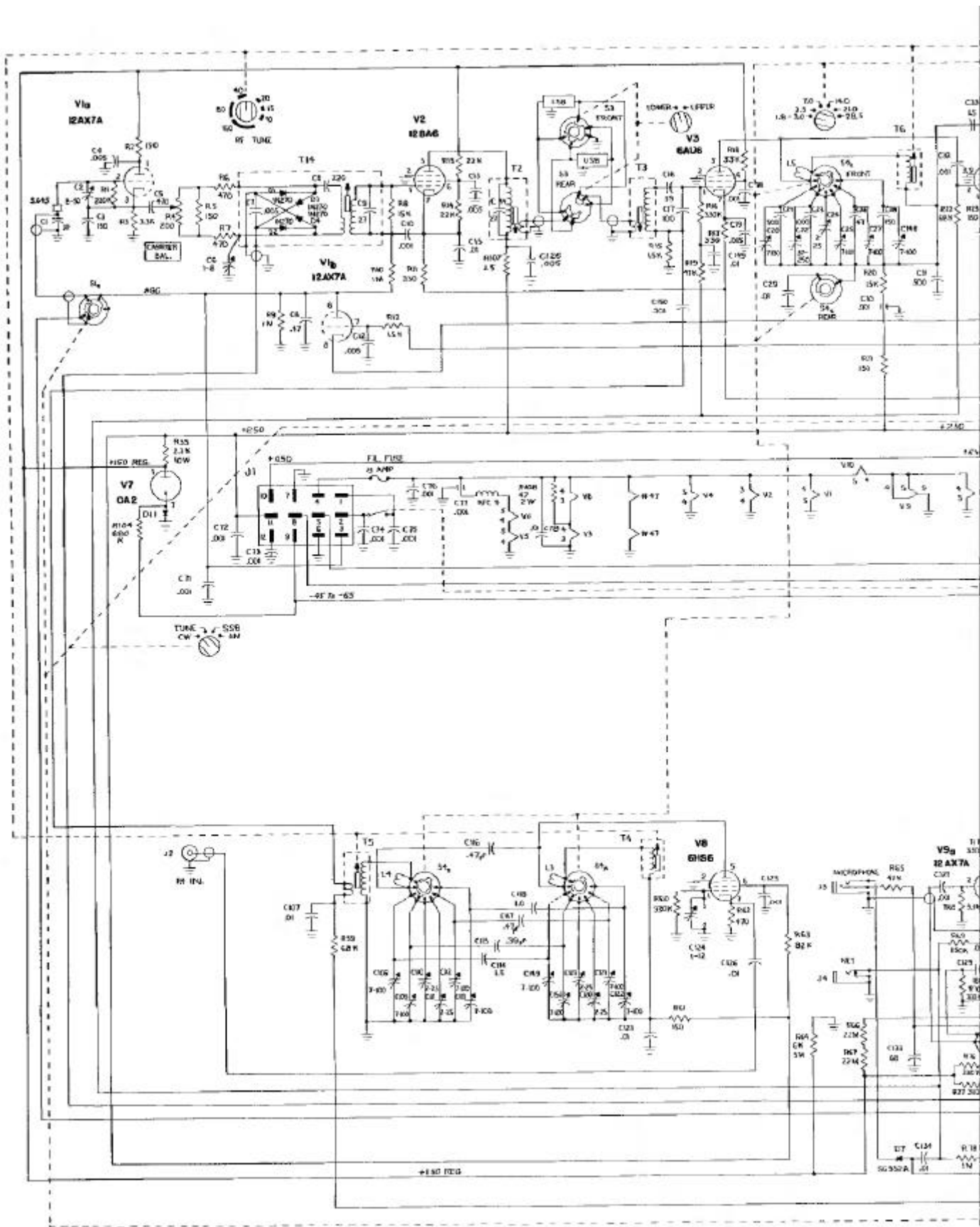
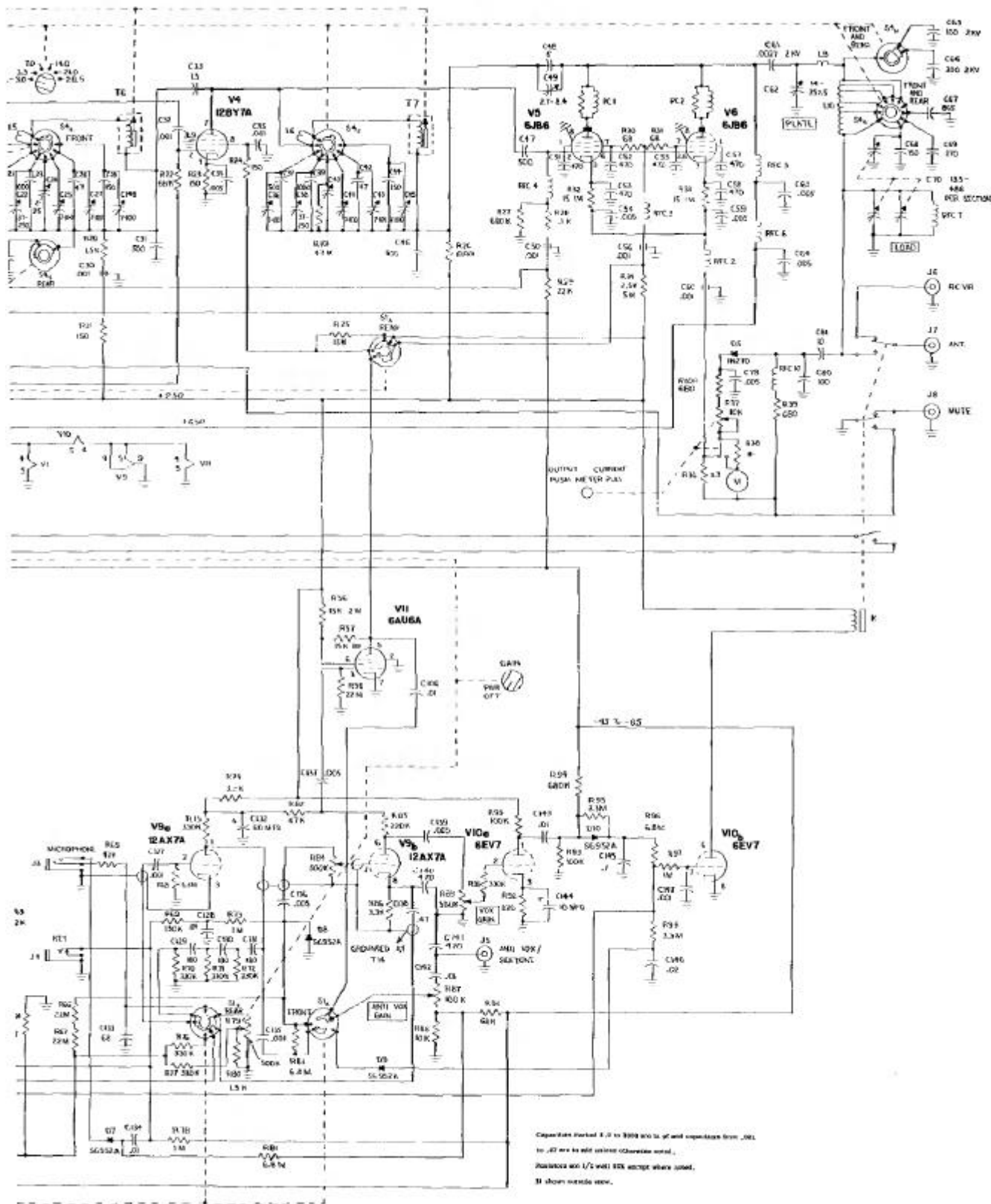

Fig. 17



SCHEMATIC DIAGRAM MODEL T-4 R



AM MODEL T-4 RECITER

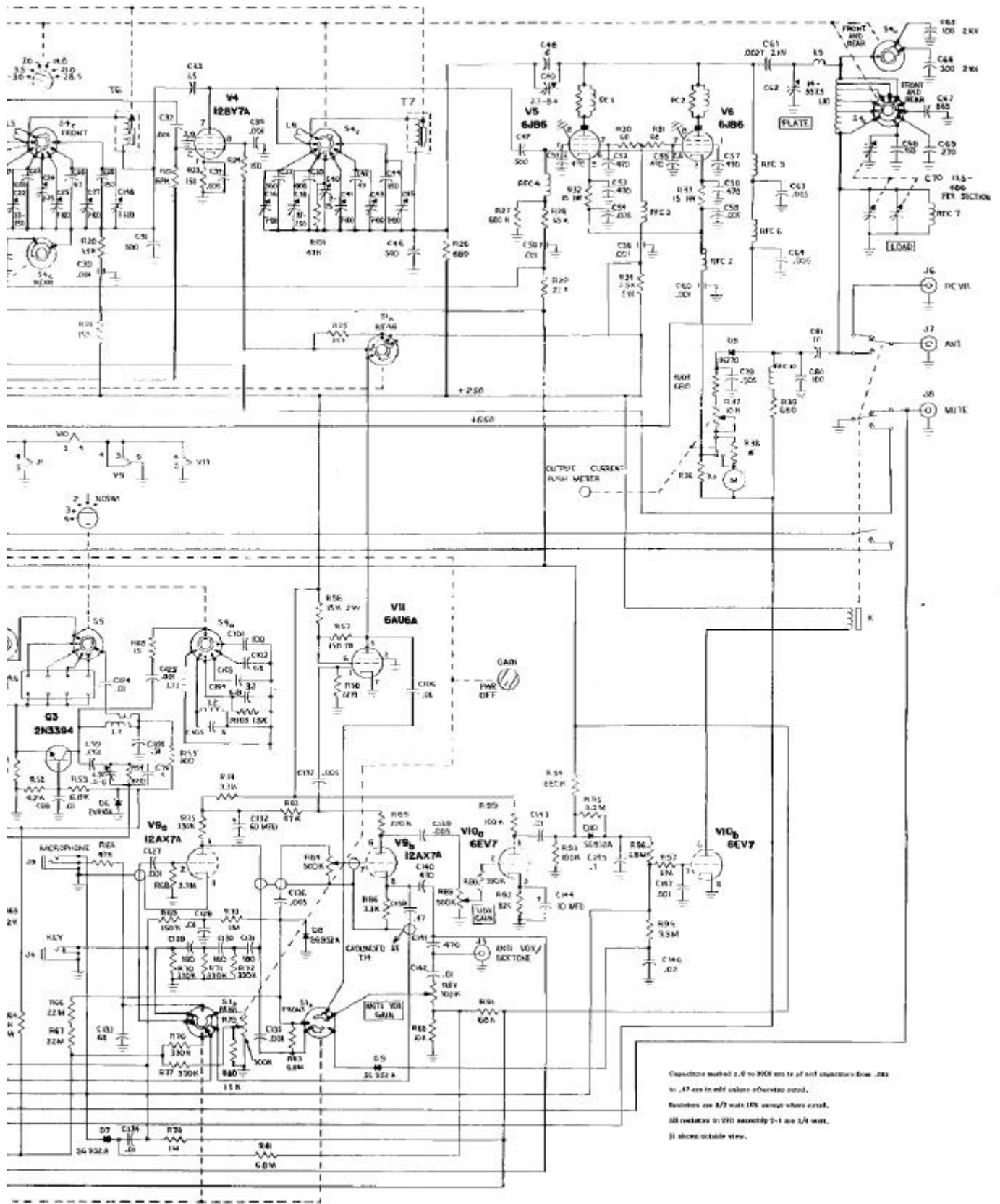

MODEL T-4X TRANSMITTER